

CAMBO

Wide RS 1600 series

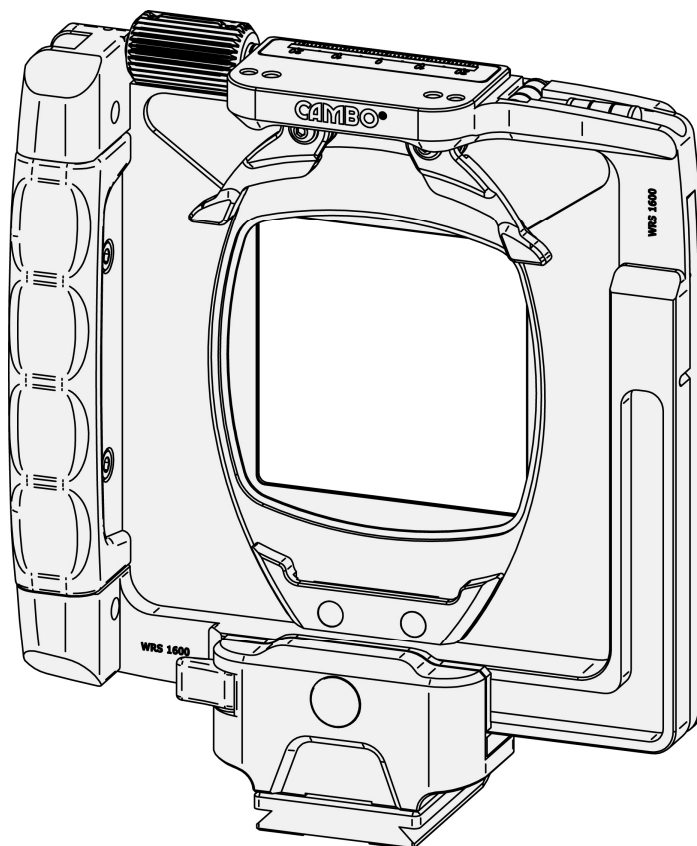

E

INSTRUCTION
MANUAL

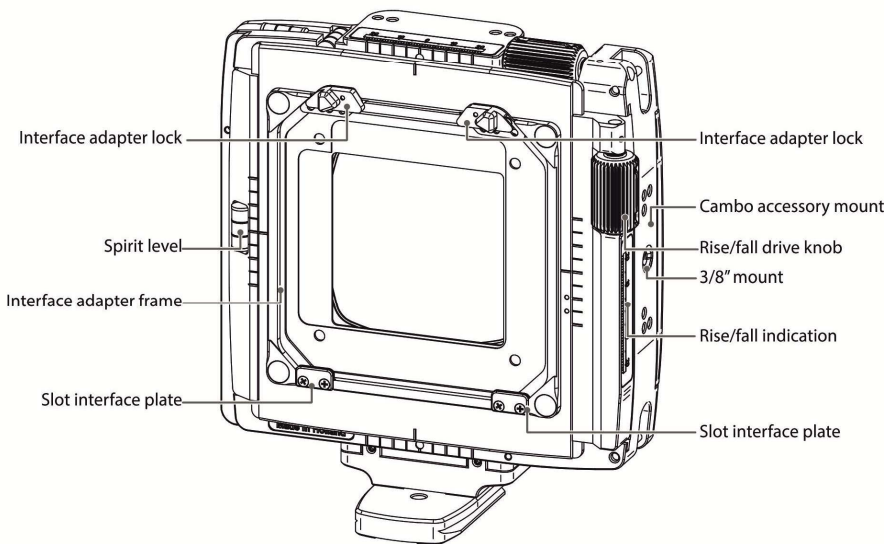
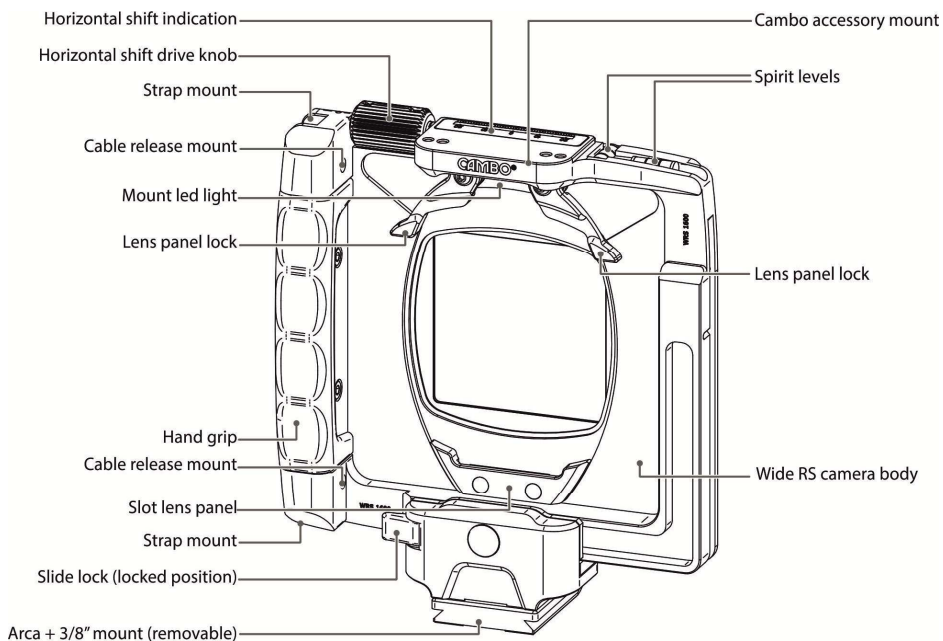

Thank you for purchasing a Cambo product.

The Wide RS is a compact medium format system camera featuring lateral and vertical shift of the rear standard. The precision rear shift/rise and fall control is ideal for architecture and landscape photography. It enables the photographer the use perspective control, image displacement and high-quality panoramic stitching. A unique feature of the WRS-1600 is its ability to rotate the full camera/lens/back assembly in the tripod mount between landscape and portrait mode within seconds.

Key Features:

- Small size 180 x 160mm (W x H)
- Lightweight only 0.92 kgs (excl. lens)
- High grade aluminum camera body and shift plates
- Horizontal shift 40mm (20mm left/20mm right)
- Vertical shift 40mm (20mm / 20mm)
- Stitching possibilities (2-way / 4-way)
- Accelerated precision spindle gear drive
- Millimeter movement indicator
- Movement indicators on rear sides
- Sensible click indication at 5, 10 and 15mm
- Compatible with WDS and Wide Compact
- Integrated hand grip
- Removable cable release (included)
- Removable Arca plate
- 3 integrated spirit levels
- Accessory mount for 2 point fixed accessories
- LED light (included)
- Compact soft case (included)
- Broad range of optics
- Retrofitting of user lenses offered

A. MOUNTING THE LENS PANEL

The Wide RS system is compatible with the Cambo WDS/WTS lens panels.

1. Open both *lens panel locks*
2. Slide the bottom of the lens plate into the *lens panel slot*
3. Tilt the lens panel flat to the camera body
4. lock both *lens panel lock*

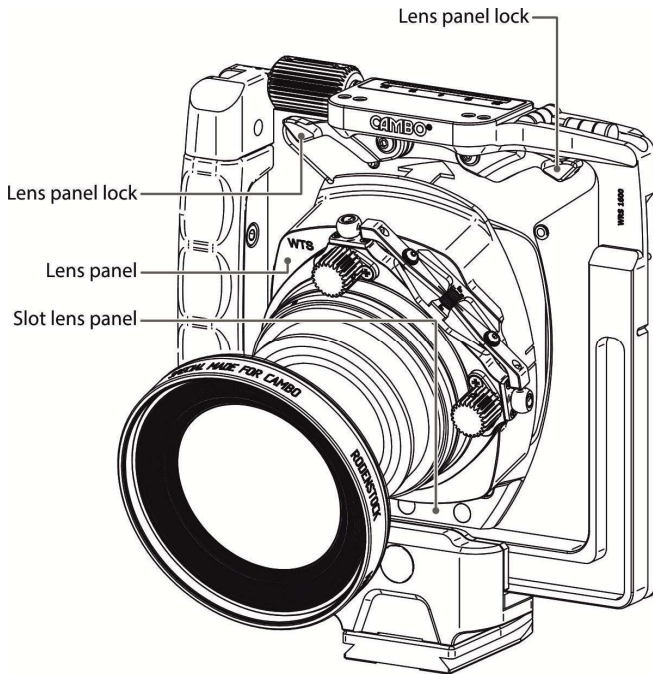

B. MOUNTING AN INTERFACE ADAPTER

The Wide RS system is compatible with the Cambo SLW interface plates. The available interface (adapter) plates are:

<i>Interface plate</i>	<i>Compatible mount</i>
SLW-80	Hasselblad®-V
SLW-81	Leaf® AFi, Sinar® HY6
SLW-83	PhaseOne® (including IQ3 series)
SLW-88 (discontinued)	PhaseOne®, Mamiya® 645 AFd
SLW-87	Contax® 645
SLW-89	Hasselblad®-H
WRS-1068 (SLW mount)	Mamiya® RB roll film holder

Note: all interface plates are interchangeable.

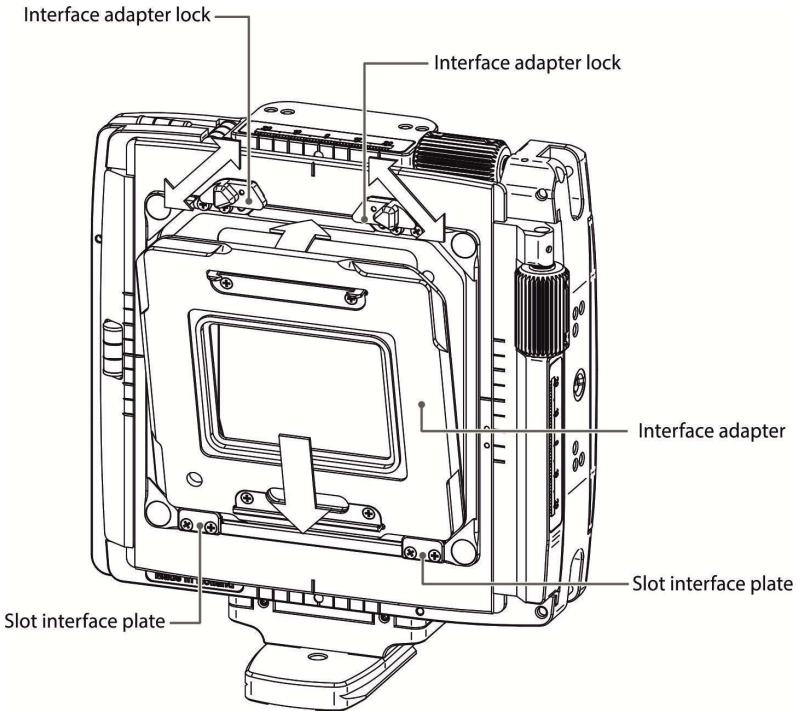

C. CABLE RELEASE AND SHUTTER

The hand grip features two cable release sockets. The cable release must be attached to the release socket/lever of the mechanical shutter. All WDS/WTS lens panels feature a Copal 0 shutter, with shutter speeds between 1/500 and 1 second, B and T. The mechanical shutter must be cocked between every exposure. The Rodenstock® electronic shutter is available on request.

D. MOUNTING THE DIGITAL BACK

Please choose the SLW interface adapter corresponding to the interface mount of your digital back. The digital back is mounted to the SLW adapter as it would to corresponding medium format camera body (Hasselblad®-V, Mamiya® AFd, Leaf® AFi, etc.). To synchronize the digital back with the mechanical/electronic shutter please use the brand specific “synchro release cable”. For further operating details please follow the instructions of the manufacturer of the digital back.

E. MOVEMENTS: SHIFT, RISE AND FALL

The Wide RS features horizontal as well as vertical (rise/fall) movement of the rear standard. These movements can be used for perspective control, image displacement and stitching of multiple exposures. This allows the user to take full advantage of the large image circle of certain lenses. Both movements shift the image plane, which allows the user to take multiple images within the same focal plane, ideal for stitching. Stitching can be used to create panoramas with the maximum viewing angle or to create higher resolution files.

The horizontal shift is operated by drive knob located at the top of the camera. From the optical center position the rear standard can be moved 20mm left or 20mm right. The vertical shift (rise/fall) is operated by drive knob which is located at the right hand side of the camera. From the optical center position the rear standard can fall 20mm (shifts the image up) or rise 20mm (shifts the image down).

Please note that above movements are the mechanically feasible movements, which do not by default reflect the optical possibilities of all lenses. Each lens has its own possibilities and limits.

F. MOVEMENTS AND SCALES

The horizontal movement can be referred at the millimeter scale at the top of the camera body (1mm scale). The vertical movement can be referred at the millimeter scale at the side of the camera body. Another way to refer the amount of shift movement is using the engraved markings on the backside of the housing (5mm scale).

G. LANDSCAPE/PORTRAIT ROTATION

The Wide RS 1600 series comes with a sliding mount block. This enables the user to change the camera orientation from landscape to portrait orientation and vice versa within seconds.

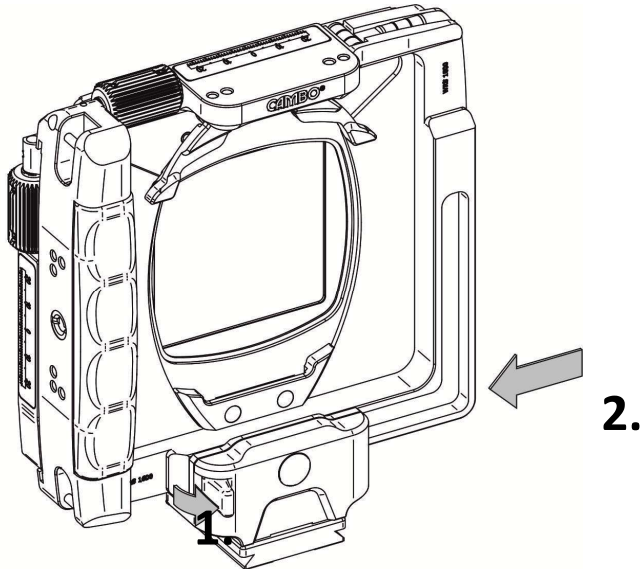

! **Warning: don't force the rotation of the camera body when the rotation axis is not positioned (all the way) at the end stop, this could damage the rotation axis or camera body.**

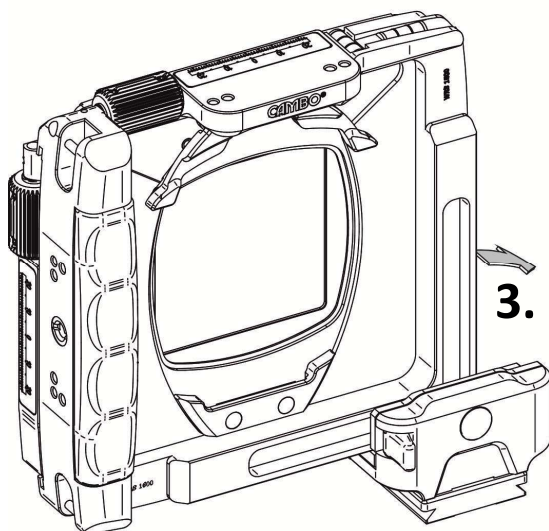

To rotate from landscape to portrait, please unlock the slide lock lever [1]. Now you can slide [2] the camera body to the left (front side view) until it hits the end stop. Now please rotate the camera body 90 degrees clockwise [3]. Now you can slide the camera to the left again until it reaches the 0-position. To fix this position please lock the slide lever [5].

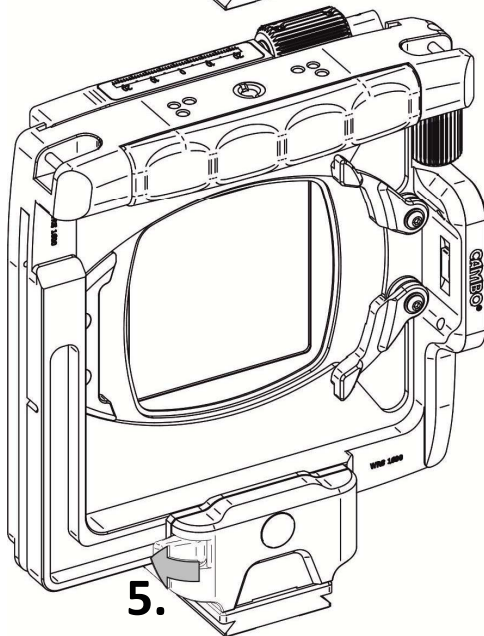
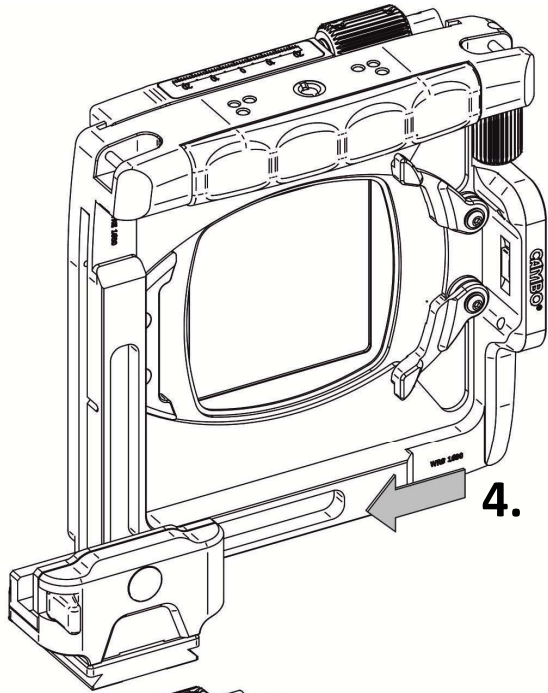

H. ACCESSORY MOUNT, VIEWFINDER AND COMPENDIUM

At the top of the camera body features the Cambo accessory mount. The Cambo accessory modules are mounted using a two-way fixation, which results in an accurate and stable fixation.

The available Cambo modules are:

- WRS-1060 Apple® Iphone® viewfinder holder (*Iphone® 4 and 5 series*)
- WRS-1075 Module with an universal accessory shoe mount
- WRS-1080 Optical wide angle (120 degree) viewfinder (*optional masks*)
- WRS-1090 Compendium

I. LED LIGHT MODULE

The Wide RS system includes a removable LED light which is convenient for use in darker environments when reading the distance scale, aperture and shutter speed. The LED unit attaches to the magnet positioned under the accessory mount of the camera body.

The LED module can be set to different lighting modes. Standard the LED module is in “demonstration mode”, which means it will turn off automatically after four seconds. To change the LED module to “constant light mode” press and hold the button until the light turns off (at least 20 seconds).

Press the button to turn the light ON or OFF. Press and hold to change the brightness of the LED. The LED unit uses CR-2016 lithium batteries, to replace the batteries, the housing can be opened at the base by the key ring (note small notch in key ring hole).

J. USE OF LENS PANELS

Each lens has a defined image circle and viewing angle specified by the lens manufacturer. The indicated image circle is defined by the circle containing acceptable image quality, defined by the quality standards of the lens manufacturer. Cambo does not change these specifications. For detailed lens specifications users are referred to data provided by Rodenstock® or Schneider Kreuznach®. The maximum image displacement, to keep the

image inside the specified image circle, depends on the size of the image circle and the image sensor used.

In this example we use a digital back with a CCD size of 48x36mm. When we use a lens with a image circle of 70mm, like the Rodenstock® 5,6/23HR Digaron-S, the maximum horizontal shift is 6mm (to either side) and the maximum rise or fall is 7,5mm. When we use a lens with a image circle of 90mm, like the Schneider® 5,6/35 XL Apo-digital, the maximum horizontal shift is 17mm (to either side) and the maximum rise or fall is 20mm.

K. WTS TILT-SWING LENS PANELS

The WTS panel allows an angle adjustment between +5 and -5 degrees in both swing and tilt direction for setting Scheimpflug corrections. These can be used separately as well as simultaneously, using the 2 adjustment knobs. The lens plane and CCD are parallel when the tilt (T) and swing (S) indicators are set to zero on the scale. This zero-position is reached when the bearing snaps into the lock, where the drive knobs become slightly loose by purpose.

To apply tilt only use tilt knob, to apply swing only use swing knob. When needed, a combination of both can be applied.

Note: do not force beyond the +5/-5 boundary marks.

L. LENS CAST

Under certain circumstances there may be occurrence of lens cast, caused by the light striking the CCD under an angle due to either shifts or very short focal length. The effect may differ quite a lot from one CCD to another and is not a constant factor. This effect is acknowledged by all digital back manufacturers and each have their own software solution for this.

This instruction manual has been prepared with care. However, Cambo Fotografische Industrie BV can accept no responsibility, financial or other for any consequences arising out of the use of this material.

All specifications in this manual are subject to change without notice. Please check www.cambo.com for updates.

Cambo is a registered trademark. All other mentioned trademarks are owned by their specific owners.

CAMBO

Fotografische Industrie BV

P.O. Box 200

NL-8260 AE Kampen Email:

The Netherlands

Tel. +31 383314644

Fax. +31 383315110

info@cambo.com

Web: www.cambo.com

© Cambo 2016. All rights reserved.