

Cactus[®]

User Manual

**Laser
Trigger
LV5**

Table of Contents

1. Main Features of Cactus LV5	02
2. Caution and Warning	02
3. Major Specifications	03
4. Package Contents	04
5. Nomenclature	05
6. Setup	07
7. Basic Operation	14
8. Advanced Operation	19
9. LED Status Outline	28
10. Optional Accessories	28
11. Troubleshooting	29
12. Notices	33
13. Warranty	35

1. Main Features of Cactus LV5

Thank you for purchasing Cactus LV5 Laser Trigger. Cactus LV5 is a powerful yet handy device that allows you to do creative high speed photography and camera trap wildlife photography. With this trigger, you won't miss a shot when those unexpected moments occur.

- **EXCLUSIVE! Duo Mode Triggering (DMT).** Cactus LV5 can be triggered by: (1) blocking the transmission between the laser Emitter and Sensor; or (2) removing the object between the laser Emitter and Sensor.
- **EXCLUSIVE! Works wirelessly with Cactus V5 and subsequent V5-compatible models.** Cactus LV5 combines laser and radio frequency (RF) technology in a single device. With a built-in Cactus V5 transceiver module in the Sensor, LV5 allows you to take instant camera photos with unlimited number of portable flashes, wirelessly!
- **Long working distance.** The working distance between the laser Emitter and the Sensor is up to 150 meters.
- **Works under sunlight.** The LV5 not only works under ambient light, its intelligent design also allows it to work under sunlight.
- **Supports single and continuous shots. Supports bulb shot.** The LV5 offers endless possibilities for your creative works.
- **Shutter Delay and Freeze:** Shutter delay and post-shutter freeze period adjustable in 15 divisions.

2. Caution & Warning

Before using your product, read the following safety precautions to ensure correct and safe usage and help prevent damage to the Cactus LV5.

1. Keep out of reach of children.
2. CLASS 1 LASER PRODUCT. – Avoid direct eye exposure at all times.

Class 1 laser cannot emit accessible laser radiation levels in excess of the acceptable emission limit (AEL) within the inherent design or intended use of the laser. It does not pose a hazard under normal operating conditions as designed and intended.

3. Remove protective film on the LV5 Sensor for best performance.
4. Turn OFF all your equipments (e.g. Cactus units, flash units, and cameras, etc.) before changing batteries or making connection. Observe the correct polarities when changing batteries. There is danger of possible explosion if batteries are installed incorrectly.
5. Switch off the LV5 and remove batteries during storage.
6. Do not permanently store the product in a high temperature environment (e.g. under strong direct sunlight, inside an automobile, near cooking stoves/ovens).
7. Do not operate the device in the presence of flammable gases or fumes.
8. The Cactus LV5 should never be submerged in liquid or exposed to rain unless it is properly protected.
9. Never drop or allow the devices to hit the floor.
10. ONLY use the product as described in the user manual. Improper use of the product may damage the LV5.

3. Major Specifications

- Working radio frequency: 2.4GHz
- Number of radio channels: 16
- Selectable laser frequencies:
 - (1) 500Hz
 - (2) 1KHz
- Supported sync speed: Up to 1/1000s
(subject to the camera's sync speed limitation)

- Effective distance between Emitter and Sensor:
 - (1) 150m in dark environment
 - (2) 20m under strong and direct sunlight
- RF effective distance: 0.3m to 100m
- Operating temperature: -20°C to +50°C (-4°F to 122°F)
- Camera voltage handling: 0V to 6V
- Power input: Operates with 4 or 8AAA 1.5V batteries
- Angle lock tilt: 20° down to 65° up
- Dimensions:
 - Emitter: 92mm (L) x 80mm (W) x 93mm (H)
 - Sensor: 153mm (L) x 80mm (W) x 93mm (H)
(including hood)
- Weight:
 - Emitter: 135g
 - Sensor: 175g (including hood)

4. Package Contents

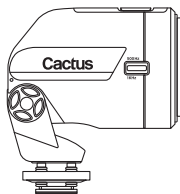

LV5 Emitter

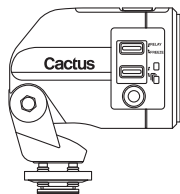

LV5 Sensor

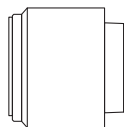

LV5 Hood

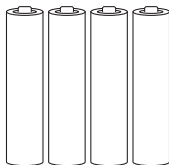

AAA batteries



3.5 mm cable
PC sync cable

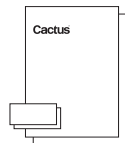

User manual,
Poster &
Delay/Freeze Sticker

5. Nomenclature

5.1

LV5 Emitter

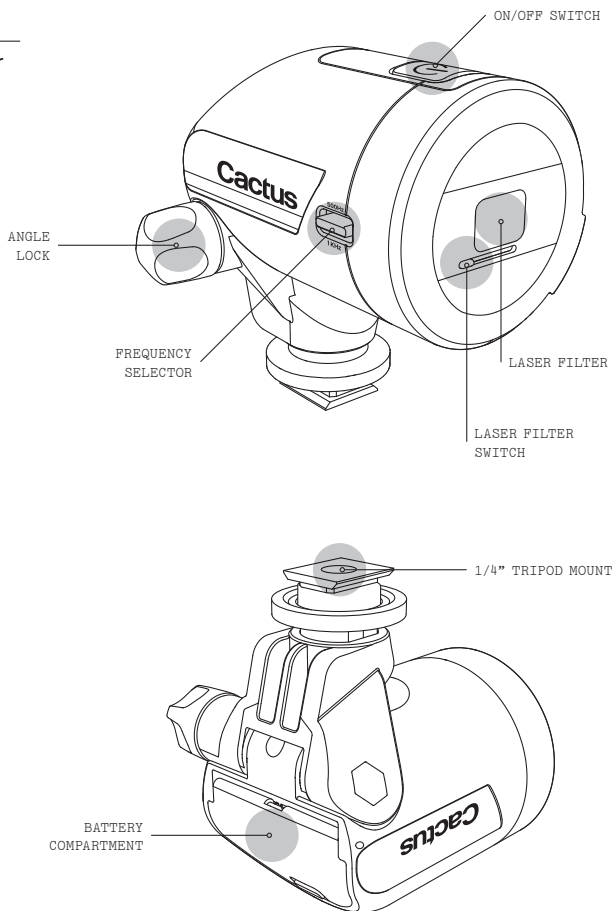



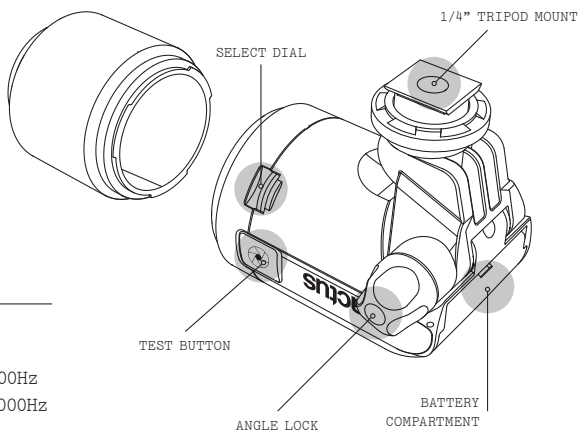
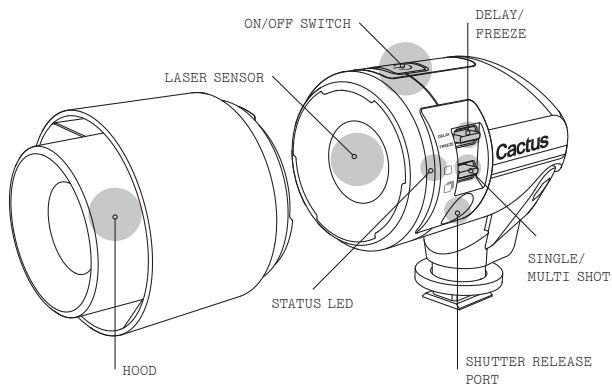

5.2

LV5 Sensor



Glossary

500Hz	Frequency 500Hz
1KHz	Frequency 1000Hz
	Single Shot
	Multi Shot
	Test Button
	ON/OFF Switch

5.3

Compatibility

1. LV5 works with all SLR and DSLR cameras that come with a shutter release port.

The shutter release function of the LV5 requires the use of a separately purchased shutter release cable for connection between the LV5 and the camera. This cable is NOT included.

For a list of optional accessories, see Section 10.

2. Different cameras vary significantly in duration they need to respond to a shutter signal. In speed photography where events happen in rapid sequence under extremely short duration of time, only cameras with fast response time could capture the precise moment(s). Cameras with slower response time may only capture events that happen throughout a longer duration and/or in slower sequence.

6. Setup

6.1

Installing Batteries

6.1.1 Four AAA batteries

1. Open the battery door by pulling the latch.
2. Insert four (4) AAA batteries into the battery compartment.
3. Insert the batteries with the correct polarities by referring to the +/- signs indicated on the battery compartment.
4. Close the battery door after batteries are installed.

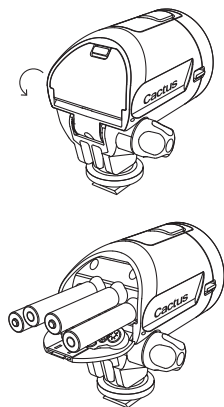

6.1.2 Two AAA batteries

The LV5 can also operate using only two (2) AAA batteries, but you must insert them in pairs as depicted on the right.

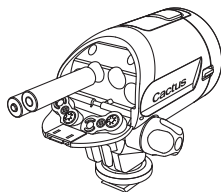
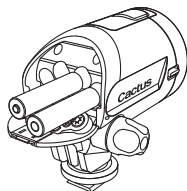

6.1.3 Battery Consumption:

		BATTERY LIFE* (HRS)	
		2 X AAA	4 X AAA
LV5 EMITTER		40	80
LV5 SENSOR	STANDBY	90	180
	TRAP MODE OPERATION	85	175
	ESCAPE MODE OPERATION	60	125

* Battery consumption based on battery capacity of 1000mAh

Note: The LV5 works with Alkaline and NiMH batteries. Battery life will depend on the capacity and quality of batteries used.

6.2

Mounting to Light Stand, Tripod, or Umbrella Swivel

There are a few ways to install the LV5 Emitter and Sensor:

1. Light stand: Mount the LV5 by using the standard 1/4" tripod mount. Rotate the unit until it is secured in place.
2. Tripod (via quick release plate): Mount the LV5 to the tripod screw on the quick release plate. Secure the mount by turning the lock from the underside of the quick release plate.
3. Umbrella swivel with hot shoe mount: Mount the LV5 to the hot shoe mount and secure it by tightening the hot shoe lock.

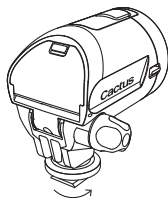

Note: Stone bags are recommended for added weight and security on the light stand/tripod.

6.3

Adjusting Tilt Angles

1. Loosen the Angle Lock.
2. Set the LV5 to the required tilting angle (from 20° down to 65° up).
3. Tighten the angle lock when done.

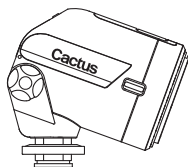
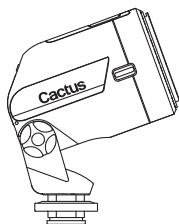

6.4

Using the Bayonet Mount

6.4.1 Installing the Hood

1. Attach the Hood using its bayonet-style mount to the Sensor.
2. Align the white dots on the Sensor and Hood. When they are in place, turn the Hood clockwise to lock it.
3. Turn the Hood counter-clockwise to detach it.

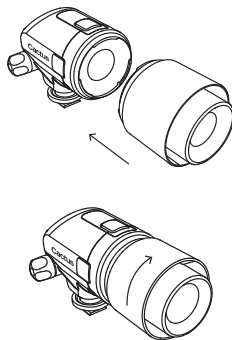

6.4.2 Storing the LV5 system

1. Remove the Hood if it is mounted on the Sensor.
2. Align the centre of the LV5 Emitter On/Off Switch to the white dot on the rim of the LV5 Sensor. When they are in place, turn the Emitter clockwise to lock it.
3. To detach the Sensor from Emitter, turn the Emitter counter-clockwise.

6.5

Frequency Selector

There are 2 frequencies available on the LV5:
500Hz and 1KHz (1000Hz).

ALWAYS choose 1KHz under normal shooting circumstances.
Use 500Hz ONLY when the laser beam is being interfered by other light source in the environment.

To select frequency:

1. Use Frequency Selector on the Emitter to select the desirable frequency.
2. Pair up the Emitter with the Sensor.

3. When the Sensor detects the laser beam from the Emitter, it will automatically detect the selected frequency and perform accordingly.
4. **To change frequency subsequently, switch OFF the Sensor.** Select the desirable frequency using the Frequency Selector on the Emitter. Pair up the Emitter with the Sensor again, then switch the Sensor ON. The Sensor will automatically detect the new selected frequency and perform accordingly.

6.6

Select Dial on LV5

Different from the channel dial on Cactus V5, **the select dial on LV5 is a multi-functional dial for (1) RF channel and (2) Delay and Freeze time setting.**

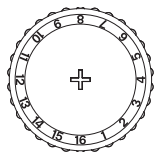

1. **SET RF channel when LV5 is OFF:** If you pair up the LV5 Sensor with an V5 transmitter, set the channel on the LV5 Sensor with the Select Dial BEFORE switching it ON. If you do not wish to set Delay time or Freeze time, dial back to 1 as soon as the LV5 is switched ON.
2. **Set Delay and Freeze time when LV5 is ON:** Once switching on, set Delay and Freeze time by the Delay/Freeze switch and the dial selector (follow steps in Section 8.2).

6.7

Connecting LV5 Sensor to the Camera

6.7.1 Direct Cable Connection

1. Connect the shutter release cable (optional) to the Sensor's shutter release port.
2. Plug the other end of the shutter release cable to the camera's shutter release port.
3. The Sensor sends a signal to the camera directly via the shutter cable, so the distance between the Sensor and the camera is limited by the length of the shutter release cable.

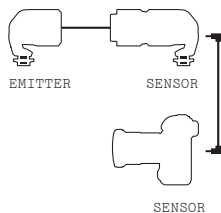

6.7.2 Cactus V5 Wireless Shutter Release

1. Connect the shutter release cable (optional) to the Cactus V5 X-Sync Port.
2. Plug the other end of the shutter release cable into the camera's shutter release port.
3. Adjust both the Sensor and the V5 Receiver (RX) to the same channel by using the channel dial **BEFORE SWITCHING ON THE SENSOR.**
4. The Sensor sends a radio signal to the V5, but be sure to place the camera within the 100m suggested operating distance.

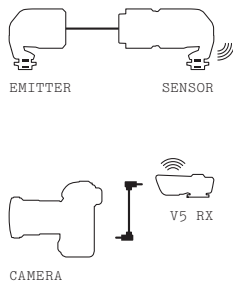

5. Cactus V5's Multi-Channel Triggering also applies to LV5, triggering up to four (4) groups of V5 transceivers separately or all at once. To make use of the multi-channel triggering feature, set LV5 to Channel 1 and V5 transceivers to a channel in blue (i.e. Channels 1 to 5)

6.7.3 Third-Party Wireless Shutter Release

1. Connect a third-party wireless shutter release transmitter to the Sensor using a 3.5mm shutter release cable.
2. Plug the third-party wireless shutter release receiver to the camera's shutter release port.
3. The Sensor sends a signal to the third-party transmitter, so distance between LV5 and the camera depends on the operating distance of the third-party wireless shutter release.

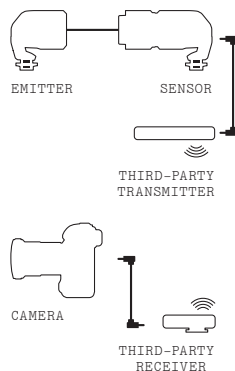

7. Basic Operation

7.1

Before Use

Pair up the Emitter and Sensor within 1m by aiming the laser at the Sensor until you see a steady green LED.

Tips: To prevent the laser beam -- i.e., typically a red spot on your subject -- from appearing in your images. Position the laser so that it hits the subject on the side facing away from the camera.

7.2

LV5 Trap Mode

7.2.1 Single Shot

LV5 triggers the camera to take one shot when laser signal is intercepted.

1. Set the Sensor to **Single Shot**.
2. **Switch on your camera and set the drive mode to Single Shot** (see your camera's user manual for corresponding function key).
3. Connect the Sensor to the camera (see Section 6.7).
4. Place the Emitter and Sensor to the desired location and adjust the angle of the laser path so that the Sensor can detect the laser like the image below:

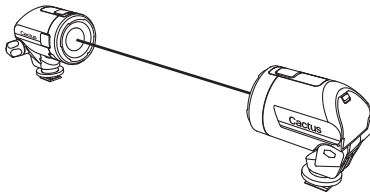

5. Switch on both the Emitter and Sensor by pressing the ON/OFF switch once. The Sensor status LED blinks green every 3 seconds.

Caution: Do not point the laser at your eyes.

6. Aim the Emitter laser at the Sensor. When the laser is detected, the blinking LED turns to a steady green and the LV5 is ready to use. If the laser is never detected, the LED continues to blink green every 3 seconds. Aim again until the LED turns steady green.
7. Press the Test Button on the Sensor to confirm the shutter cable or wireless connection with your camera. At half-press, LED turns orange and camera will auto focus; at full-press LED turns green, shutter releases and the camera takes a shot.
8. When an object passes through the laser, the LV5 triggers the shutter of your camera and takes a shot (delay may occur depending on camera model and lens focusing speed).

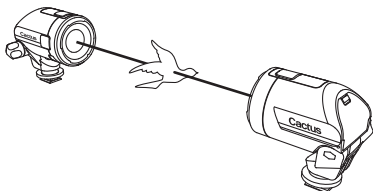

9. When the laser signal is once again detected by the Sensor, the LED turns steady green and is ready for the next shot when an object passes through the laser.

7.2.2 Multi Shot

LV5 triggers the camera to take multiple shots when laser signal is intercepted.

1. Follow steps in Section 7.1.
2. Set the Sensor to **Multi Shot**.
3. **Set the camera's drive mode to burst/continuous/high speed mode** (refer to your camera user manual for corresponding function key).

4. Setup is complete and the equipment is ready for use.
5. When an object passes through the laser and blocks the Sensor from detecting the laser, the LV5 triggers the camera to start taking multiple shots until the object no longer blocks the laser.
6. Once the laser signal is detected by the Sensor again, the LED turns green and LV5 is ready for the next group of multiple shots.
7. Follow the same procedures and set camera's shutter speed to Bulb to take **Bulb exposure shots**. When an object passes through the laser, the LV5 triggers the camera to open its shutter. When the object no longer blocks the laser, the LV5 triggers the camera to close its shutter.

7.3

LV5 Escape Mode

LV5 triggers the camera shutter when an object moves away from the laser signal.

Make sure the Sensor is OFF. Press and hold the ON/OFF Switch for 5 seconds. The Sensor is ready and functions in Escape Mode when the LED is steady red.

To cancel Escape Mode, switch off the Sensor.

7.3.1 Single Shot

1. Connect the Sensor to your camera.
2. Switch on the Emitter. The Status LED blinks orange every 3 seconds.
3. When the laser is detected, the Status LED light turns to steady orange.
4. Place the object between the Emitter and Sensor, blocking the laser. The Status LED turns red. The LV5 is now ready.
5. Once the object moves away and the laser is detected again by the Sensor, the camera's shutter releases and takes one shot.

7.3.2 Multi Shot

1. Follow steps 1-4 outlined in Section 7.3.1 but set the Sensor to Multi Shot and the camera's drive mode to burst/continuous/high speed mode (refer to your camera's user manual for corresponding function key).
2. When the laser is detected by the Sensor again, the camera's shutter releases and takes multiple images until the object blocks the laser.

7.4

Setting the LV5 for Outdoor Use

Outdoor environments have high luminosity level and the brightness around the LV5 could affect laser detection between the Emitter and the Sensor. The maximum tested distance of LV5 under direct sunlight is 20m. To set your LV5 for outdoor shooting, perform the steps below.

1. Pair up the Emitter and Sensor within 1m by aiming the laser at the Sensor until you see a steady green LED in Trap Mode.

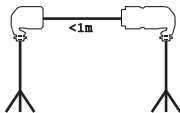

2. Place the Emitter and Sensor at a desirable distance. Mount the LV5 units securely on light stands or tripods, and adjust them to similar heights. (see the image below). Place a black card in front of the Emitter and a clear red dot appears on the card.



3. Slowly move the black card away from the Emitter towards the Sensor.

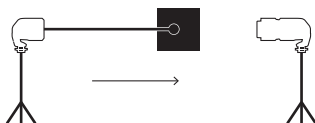

Note: The further away the black card is from the Emitter, the lighter and larger the red dot appears.

4. When the black card reaches the Sensor, take note of the approximate location of the red dot and adjust the height and angle of the Sensor to match the same dot. Remove the black card. If the laser is detected by the Sensor, the status LED will turn from blinking to steady.

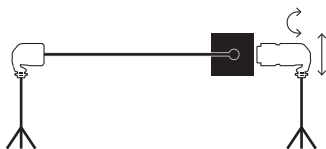

7.5

Off Camera Flash with Cactus V5

Add creative lighting effects to your photos by using Cactus V5 transceivers and portable flash units. Set one V5 as Transmitter (TX), mount it on the camera's hot shoe, and set additional V5 transceiver(s) as Receiver (RX) for portable flash unit(s).

In this case, set the V5 transceivers used as wireless flash trigger to a different channel other than what you are using for the LV5/V5 wireless shutter release.

7.6

Suggested
LV5 Setup
with Cactus
V5 Wireless
Flash
Transceiver

Option 1:

1. Connect the Sensor to camera by shutter cable (optional).
2. Mount V5 TX to camera hot shoe and flash to V5 RX, both set to the same channel.

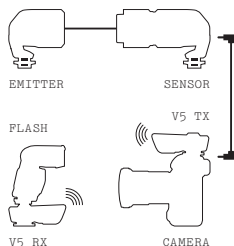

Option 2:

1. Use the Sensor's wireless function by pairing it with a V5 RX. Set both to the same channel (e.g. Ch 5).
2. Connect this V5 to camera by a shutter cable (optional).
3. Set the pair of V5 used for wireless flash to a different channel (e.g. Ch 16).

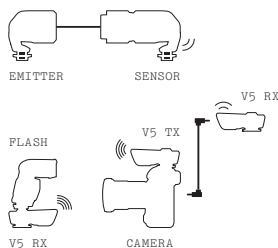

8. Advanced Operation

In certain situations, when **(1) you need a pause** between the LV5 detecting an event and the moment the image is taken; **(2) you want to manipulate the length of a shutter signal** to trigger devices with different response time; or **(3) you want to stop the LV5 from responding to subsequent Events** for a certain period of time after an image was taken, two timer functions of the LV5 – **Delay and Freeze** – can be used to achieve these goals.

8.1

Basic Concepts

Event:

An Event begins when an object blocks the laser beam in Trap Mode (or leaves it in Escape Mode). An Event ends when the laser beam is not blocked anymore in Trap Mode (or is blocked again in Escape Mode). **An Event therefore has a duration that can range from very short to very long.**

Shutter Open Signal :

Signal transmitted from the LV5 to the camera which commands the camera shutter to open.

Shutter Close Signal :

Signal transmitted from the LV5 to the camera which commands the camera shutter to close **ONLY when the camera is in Bulb or Burst mode.** If the camera is not in Bulb or Burst mode, Shutter Close Signal will not affect the shutter duration of the camera.

Delay:

An image is not taken immediately but after a set Delay time. **Set a Delay time when you want to capture a moment later than the Event actually happens.**

Freeze:

After an Event has been detected, the LV5 can ignore further Events for a specified amount of time. **Set a Freeze time if you want to avoid further images to be taken after a principle event occurred.** Freeze can be achieved in LV5 by:

1. Shutter Pause: In Single Shot, LV5 will send shutter open and close signal at a length according to the Freeze value selected by user. No new events can trigger LV5 during the Freeze period.



2. Sleeping: In Multi Shot, LV5 will send a Shutter Close Signal at Event End. During the Freeze period after shutter closes, LV5 ignores all Event happening. The Freeze setting does not affect the length of shutter signal.

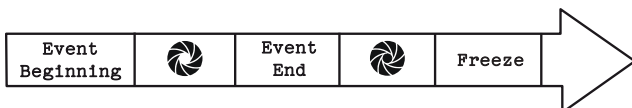

8.2

Set and Reset Delay and Freeze Values

1. **To disable the Delay and Freeze functions, make sure the LV5 Sensor is ON.** Turn the Select Dial to position 1, then slide the Delay/Freeze switch to either direction once.
2. **To set a Delay time, slide the Delay/Freeze switch to Delay, then turn the Select Dial to the Delay value you desire** (see the table in 8.2(5) for the mapping from dial numbers to time periods). If you slide the Delay/Freeze switch to Freeze afterwards, the last Delay value you have set will still be in effect. It will remain in effect until you slide the Delay/Freeze switch back to Delay, at which point the Delay time will correspond to the current dial position.
3. **To set a Freeze time, slide the Delay/Freeze switch to Freeze, then turn the Select Dial to the Freeze value you desire** (see the table in 8.2(5) for the mapping from dial numbers to time periods). If you slide the Delay/Freeze switch to Delay afterwards, the last Freeze value you have set will still be in effect. It will remain in effect until you slide the Delay/Freeze switch back to Freeze, at which point the Freeze time will correspond to the current dial selector position.
4. **Note that turning the LV5 sensor OFF will reset both Delay and Freeze values to 0.**

5. Each dial position corresponds to a Delay or Freeze value as indicated below:

DIAL POSITION	DELAY PERIOD	FREEZE PERIOD
1	OFF	OFF
2	1ms	20ms
3	2ms	30ms
4	3ms	40ms
5	4ms	50ms
6	5ms	70ms
7	7ms	90ms
8	10ms	120ms
9	15ms	180ms
10	20ms	240ms
11	25ms	300ms
12	30ms	360ms
13	50ms	600ms
14	100ms	1s
15	200ms	2s
16	400ms	4s

Tips: A sticker version of the above table is included in the LV5 package. Stick it on the LV5 Sensor for easy references.

8.3

Delay Timer
in Single
Shot

1. To set a Delay time, see 8.2(2).
2. The Delay period starts when the LV5 detects an Event Beginning. During the Delay period, the LV5 will not detect any new Events. After the Delay period has elapsed, the LV5 will send a shutter signal, causing the image to be taken.

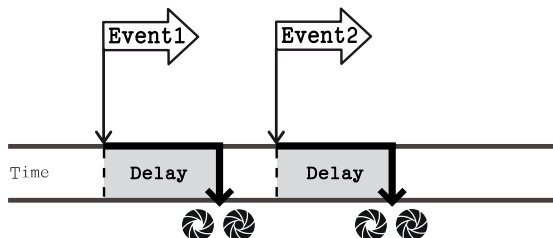

8.4

Delay Timer
in Multi Shot

1. To set a Delay time, see 8.2(2).
2. The Delay period starts when the LV5 detects an Event Beginning. After the Delay period has elapsed, the LV5 sends an Shutter Open Signal. When the LV5 detects the Event End, it starts another Delay period. After the latter has elapsed, the LV5 sends a Shutter Close Signal. During both Delay periods, the LV5 will ignore any new Events. **This scheme is designed to only shift the timing of an exposure by the Delay time, but not alter its duration.**

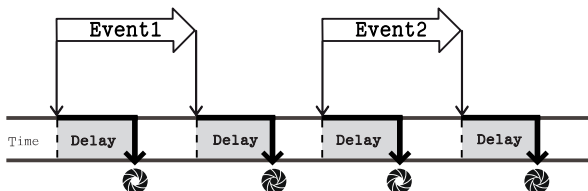

8.5

Freeze Timer
in Single
Shot

1. To set a Freeze time, see 8.2(3).
2. Different cameras vary significantly in duration they need to respond to a shutter signal. Freeze helps you manipulate the duration of shutter signal to ensure your camera has enough time to respond to an Event.
3. When Freeze timer is OFF (dial position 1), LV5 will send Shutter Open Signal upon the beginning of an Event, and Shutter Close Signal upon the end of an Event. The maximum shutter duration is capped at 500ms.
4. When Freeze timer is activated (dial positions 2-16), it determines the durations between Shutter Open Signal and Shutter Close Signal, according to the Freeze time schedule in 8.2(5).
5. Any subsequent Events that occur during the Freeze period will be ignored by the LV5, thus avoiding further, unwanted shutter signals. After the Freeze period has elapsed, the LV5 will respond to new Events again.
6. LV5 enables slow devices to capture fast events under optimum Freeze setting. See 8.9 for step-by-step instructions.

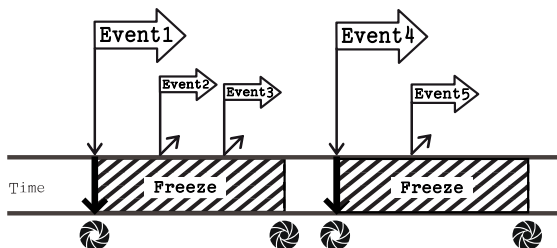

8.6

Freeze Timer
in Multi Shot

1. To set a Freeze time, see 8.2(3).
2. The Freeze period starts when the LV5 sends a Shutter Close Signal upon the Event end. During the Freeze period, the LV5 will ignore any events beginning until the Freeze period has elapsed.

3. Freeze timer in Multi Shot will not affect the duration of shutter signals.

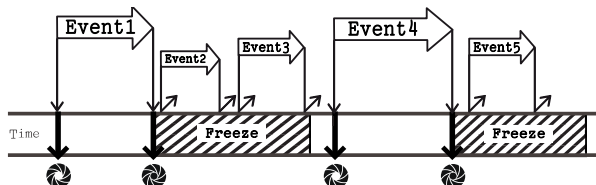

8.7

Delay and Freeze Combinations in Single Shot

1. Refer to 8.2(2) and 8.2(3) to set desired Freeze and Delay times.
2. Refer to the illustration below for how Delay and Freeze work together in Single Shot.
3. The Delay period starts when the LV5 detects an Event Beginning. During the Delay period, the LV5 will not detect any new Events. After the Delay period has elapsed, the LV5 will send a Shutter Open Signal, causing an image to be taken.
4. The Freeze period then starts after LV5 sending the Shutter Open Signal. Any subsequent Events occurring during the Freeze period will be ignored by the LV5, thus avoiding further, unwanted shutter signals.
5. After the Freeze period, the LV5 Sensor will send a Shutter Close Signal and will respond to new Events again.

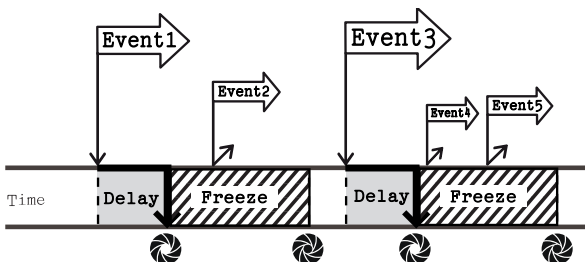

8.8

Delay and Freeze Combinations in Multi Shot

1. Refer to 8.2(2) and 8.2(3) to set desired Freeze and Delay times.
2. Refer to the illustration below for how Delay and Freeze work together in Multi Shot.
3. The Delay period starts when the LV5 detects an Event beginning. After the Delay period has elapsed, the LV5 sends a Shutter Open Signal.
4. When the LV5 detects the Event end, it starts another Delay period. After the latter has elapsed, the LV5 sends a Shutter Close Signal, causing the image to be taken. During both Delay periods, the LV5 will ignore any new Events. This scheme is designed to only shift the timing of an exposure by the Delay time, but not alter the duration of shutter period.
5. After the LV5 sending the Shutter Close Signal, the Freeze period begins.
6. During the Freeze period, the LV5 will continue to ignore any new Events beginning until the Freeze period has elapsed.
7. When the Freeze period ends, the LV5 will respond to a new Event beginning and start the cycle of Delay and Freeze again.

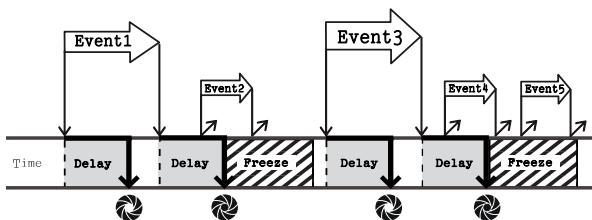

8.9

Advanced Timing: Finding the Optimum Freeze Value for Your Camera

Different cameras vary significantly in response time. In Single Shot, set Freeze timer to an optimum period that is long enough for your camera to respond and short enough to capture the maximum number of Events. The following procedure allows you to find out the optimum Freeze value for your camera.

When the optimum Freeze value is determined, do not use lower Freeze values as the camera may not be able to respond to signals shorter than that.

- (1) Turn the dial to position 1 and switch the LV5 ON.
- (2) Set the LV5 to Single Shot.
- (3) Set the LV5 to the Freeze period being tested. We suggest starting at 20ms, i.e., dial position 2 on the select dial.
- (4) Set up the LV5 Sensor in Trap Mode.
- (5) Set up the camera to the mode you will use for shooting. In general, manual exposure and manual focus are quickest. You may get different results in other modes.
- (6) Wave your hand quickly through the laser beam. If the camera fires, repeat the test 3 times.
- (7) If the camera does not fire every time when you wave your hand, increase the dial number by 1 and try again until the camera could fire every time you wave your hand. The value on the dial is the optimum Freeze time for your camera.

9. LED Signal Outline

STATUS	SENSOR INDICATOR	
	TRAP MODE	ESCAPE MODE
POWERED ON	GREEN BLINKS EVERY 3 SECONDS	ORANGE BLINKS EVERY 3 SECONDS
LASER DETECTED	STEADY GREEN	STEADY ORANGE
LASER NOT DETECTED	STEADY RED	
HALF-PRESS	ORANGE	
FULL-PRESS	GREEN	
LOW BATTERY	RED GREEN & ORANGE BLINKS EVERY 5 SECONDS	
BULB MODE ACTIVATED	GREEN LIGHTS UP FOR 2 SECONDS	
BULB MODE CLOSED	GREEN BLINKS ONCE	

10. Optional Accessories

Shutter Release Cables

1. Cactus V5 Shutter Cable for Canon Pentax Samsung SC-C1
2. Cactus V5 Shutter Cable for Canon SC-C3
3. Cactus V5 Shutter Cable for Nikon SC-N1
4. Cactus V5 Shutter Cable for Nikon SC-N3
5. Cactus V5 Shutter Cable for Nikon SC-N4
6. Cactus V5 Shutter Cable for Olympus SC-O2
7. Cactus V5 Shutter Cable for Olympus SC-OLY
8. Cactus V5 Shutter Cable for Panasonic Leica SC-PAN
9. Cactus V5 Shutter Cable for Sony Minolta SC-SON
10. Cactus Shutter Cable for iPhone (available 2013)

Wireless Flash Trigger

1. Cactus Wireless Flash Transceiver V5
2. Cactus Wireless Flash Transceiver V6 (available 2013)

11. Troubleshooting

Laser does not hit the Sensor

EMITTER LASER STATUS	POSSIBLE CAUSES	SOLUTION
NO LASER	1. BATTERIES INSTALLED INCORRECTLY	<ul style="list-style-type: none"> ENSURE CORRECT POLARITIES WHEN FITTING THE BATTERIES.
	2. INSUFFICIENT BATTERY POWER	<ul style="list-style-type: none"> REPLACE BATTERIES IN THE EMITTER.
LASER EMITS PROPERLY	3. LASER SPOT FALLS ON WRONG POSITION	<ul style="list-style-type: none"> USE THE BLACK CARD TO TRACE THE PATH OF THE LASER BEAM AND FIX THE ANGLE LOCK ACCORDINGLY. SEE SECTION 7.4.
		<ul style="list-style-type: none"> MOUNT THE EMITTER TO A BALL HEAD FOR VERY FINE ADJUSTMENTS.

Laser not detected
(assuming the laser beam does hit the Sensor)

SENSOR LED STATUS	POSSIBLE CAUSES	SOLUTION
NO LED	1. BATTERIES INSTALLED INCORRECTLY	<ul style="list-style-type: none"> ENSURE CORRECT POLARITIES WHEN FITTING THE BATTERIES.
RED GREEN ORANGE BLINKS EVERY 5 SECONDS	2. INSUFFICIENT BATTERY POWER	<ul style="list-style-type: none"> REPLACE BATTERIES IN THE SENSOR AND RETRY.
TRAP MODE: GREEN BLINKS EVERY 3 SECONDS	3. LASER FREQUENCY MISMATCH	<ul style="list-style-type: none"> RESET THE SENSOR TO DETECT THE LASER FREQUENCY AGAIN.
ESCAPE MODE: ORANGE BLINKS EVERY 3 SECONDS	4. EMITTER & SENSOR DO NOT PAIR UP	<ul style="list-style-type: none"> PLACE EMITTER AND SENSOR WITHIN 1M. ONCE LASER IS DETECTED, ADJUST DISTANCE. SEE SECTION 7.4.
	5. WEAK LASER SPOT	<ul style="list-style-type: none"> OPEN THE LASER FILTER ON THE EMITTER. ATTACH THE HOOD TO THE SENSOR FOR OUTDOOR USE.
TRAP AND ESCAPE MODE: STEADY RED	6. WEAK LASER SPOT	<ul style="list-style-type: none"> SEE POINT 5.
	7. INTERFERENCE FROM UNWANTED LIGHT	<ul style="list-style-type: none"> RE-POSITION EMITTER OR SENSOR TO AVOID UNWANTED LIGHT. CHOOSE ANOTHER LASER FREQUENCY.
	8. EMITTER AND/OR SENSOR FALLS OUT OF TRACK	<ul style="list-style-type: none"> RE-POSITION EMITTER AND/OR SENSOR UNTIL LED TURNS TO STEADY GREEN.

Camera shutter or flash not triggered with wired connection
(assuming laser is detected)

SENSOR LED STATUS	POSSIBLE CAUSES	SOLUTION
TRAP MODE: STEADY GREEN REMAINS	1. NO OBJECT HAS PASSED THROUGH THE LASER BEAM	<ul style="list-style-type: none"> RETRY WITH BIGGER OBJECT TO INTERCEPT THE LASER BEAM AT A CLOSER DISTANCE WITH EITHER THE EMITTER OR THE SENSOR.
	2. OBJECT MOVING TOO FAST	<ul style="list-style-type: none"> SWITCH THE EMITTER TO 1KHZ, RESET THE SENSOR AND RETRY. USE MORE THAN ONE LV5 TO TRAP THE OBJECT.
ESCAPE MODE: STEADY RED REMAINS	3. OBJECT STILL INTERCEPTING THE LASER BEAM	<ul style="list-style-type: none"> CHECK THE LASER BEAM AND REMOVE ANY OBJECTS.
TRAP MODE: TURNS RED (LASER IS INTERCEPTED) ESCAPE MODE: TURNS ORANGE (LASER IS DETECTED)	4. SHUTTER CABLE OR X-SYNC CABLE CONNECTION PROBLEM	<ul style="list-style-type: none"> ENSURE THE SHUTTER CABLE OR X-SYNC CABLE IS PLUGGED IN SECURELY ON BOTH ENDS.
	5. CAMERA AF SYSTEM DOES NOT FOCUS	<ul style="list-style-type: none"> SET CAMERA TO MANUAL FOCUS.
	6. CAMERA DRIVE MODE IS SET INCORRECTLY	<ul style="list-style-type: none"> ENSURE CAMERA IS SET TO THE CORRESPONDING DRIVE MODES.
	7. OBJECT MOVING FASTER THAN CAMERA'S RESPONSE TIME	<ul style="list-style-type: none"> SET CAMERA TO MANUAL FOCUS. SET FREEZE TIMER IN SINGLE SHOT TO PROLONG SHUTTER SIGNAL FOR YOUR CAMERA. SEE SECTION 8.9.

Camera shutter or flash not triggered with wireless connection (assuming laser is detected)

LED STATUS	POSSIBLE CAUSES	SOLUTION
LV5 SENSOR IN TRAP MODE: TURNS RED	1. CACTUS TRIGGER SET INCORRECTLY	<ul style="list-style-type: none"> ENSURE THE CACTUS TRANSCEIVER IS SET AS RX AND ON THE SAME CHANNEL WITH LV5. ALWAYS SET LV5 CHANNEL BEFORE POWER ON.
LV5 SENSOR IN ESCAPE MODE: TURNS ORANGE	2. BATTERIES INSTALLED INCORRECTLY	<ul style="list-style-type: none"> CHECK BATTERY POLARITIES OR REPLACE NEW BATTERIES OF CACTUS TRANSCEIVER.
V5: NO LED	3. BACKGROUND RADIO INTERFERENCE	<ul style="list-style-type: none"> SET BOTH LV5 AND V5 TO ANOTHER CHANNEL. CHANGE SETUP LOCATION AS INTERFERENCE MAY COME FROM OTHER EQUIPMENT IN THE SURROUNDING AREA.
	4. BEYOND 100-METER EFFECTIVE RANGE	<ul style="list-style-type: none"> MAKE SURE LV5 AND V5 RX ARE PLACED WITHIN 100 METERS.
LV5 SENSOR IN TRAP MODE: TURNS RED	5. CONNECTION PROBLEM BETWEEN CACTUS TRIGGER AND THE OTHER DEVICE (E.G. FLASH UNIT OR CAMERA)	<ul style="list-style-type: none"> CHECK FLASH CONNECTION AND COMPATIBILITY WITH CACTUS TRIGGER. CHECK CAMERA CONNECTION WITH CACTUS TRIGGER.
LV5 SENSOR IN ESCAPE MODE: TURNS ORANGE	6. CAMERA AF SYSTEM DOES NOT FOCUS	<ul style="list-style-type: none"> SET CAMERA LENS TO MANUAL FOCUS.
V5: GREEN	7. CAMERA DRIVE MODE IS SET INCORRECTLY	<ul style="list-style-type: none"> ENSURE CAMERA IS SET TO THE CORRESPONDING DRIVE MODES.
	8. OBJECT MOVING FASTER THAN CAMERA'S RESPONSE TIME	<ul style="list-style-type: none"> SET CAMERA TO MANUAL FOCUS. SET FREEZE TIMER IN SINGLE SHOT TO PROLONG SHUTTER SIGNAL FOR YOUR CAMERA. SEE SECTION 8.9.

12. Notices

Notices for Customers in the U.S.A.

Federal Communications Commission (FCC) Radio Frequency Interference Statements.

This equipment has been tested and found to comply with the limits for a Class B digital device, pursuant to Part 15 of the FCC Rules. These limits are designed to provide reasonable protection against harmful interference in a residential installation. This equipment generates, uses and can radiate radio frequency energy and, if not installed and used in accordance with the instructions, may cause harmful interference to radio communications. However, there is no guarantee that interference will not occur in a particular installation.

If this equipment does cause harmful interference to radio or television reception, which can be determined by turning the equipment off and on, the user is encouraged to try to correct the interference by one or more of the following measures:

- Reorient or relocate the receiving antenna.
- Increase the separation between the equipment and receiver.
- Connect the equipment into an outlet on a circuit different from that to which the receiver is connected.
- Consult the dealer or an experienced radio/TV technician for help.

HARVEST ONE LIMITED AND THE MANUFACTURER OF THIS LASER TRIGGER IS NOT RESPONSIBLE FOR ANY RADIO OR TV INTERFERENCE CAUSED BY UNAUTHORIZED MODIFICATIONS TO THIS EQUIPMENT. SUCH MODIFICATIONS COULD VOID THE USER AUTHORITY TO OPERATE THE EQUIPMENT.



FCC ID: VAAWFTLV5

MADE IN CHINA

This device complies with part 15 of the FCC Rules. Operation is subject to the following two conditions: (1) this device may not cause harmful interference, and (2) this device must accept any interference received, including interference that may cause undesired operation.

R&TTE Declaration of Conformity (DOC)

We, Harvest One Limited, 9D On Shing Industrial Building, 2-16 Wo Liu Hang Road, Fo Tan, Hong Kong, declare under our own responsibility that the product:

Cactus Laser Trigger LV5

is in conformity with the essential requirements and other relevant requirements of the R&TTE Directive (1999/5/EC).

The products are compliant with the following standards and/or other normative documents:

SAFETY	EN 62479:2010 EN 60950-1:2006
ETSI	EN 301 489-1 V1.9.2 EN 301 489-3 V1.4.1 EN 300 440-1 V1.6.1 EN 300 440-2 V1.4.1

Supplementary information:

Technical file held by:	Harvest One Limited
Place and date of issue:	Centre Testing International Corporation, Build C, Hongwei Industrial Zone, Baoan 70 District, Shenzhen, China November 9, 2012

Signed by or for the manufacturer:		9 Nov 2012
Name:	M.C. Ho	Date of Signature
Title:	Director	



This product Laser Trigger LV5 is in conformity with the provisions of EU Council Directive: 1999/5/EC.



The crossed-out wheeled bin means that within the European Union the product must be disposed separately at the end of product cycle. Do not dispose this product with other municipal waste.

13. Warranty

The limited warranty set forth below is given by Harvest One Limited in the world with respect to the Cactus brand Wireless Laser Trigger purchased with this limited warranty.

Your Cactus Laser Trigger or other contents, when delivered to you in new condition in its original container, is warranted against defects in materials or workmanship as follows: for a period of one (1) year from the date of original purchase, defective parts or a defective Laser Trigger returned to our authorized dealers, as applicable, and proven to be defective upon inspection, will be repaired with new or comparable rebuilt parts or exchanged for a new Laser Trigger as determined by Harvest One Limited or the authorized dealers.

This limited warranty shall only apply if the Laser Trigger is used in conjunction with compatible camera and flash equipment, as to which items, Harvest One Limited, shall have no responsibility.

This limited warranty covers all defects encountered in normal use of the Laser Trigger, and does not apply in any of the following cases:

- (a) Loss of or damage to the Laser Trigger due to abuse, mishandling, improper packaging by you, alteration, accident, electrical current fluctuations.
- (b) Failure to follow operating, maintenance or environmental instructions prescribed in Cactus user's manual.
- (c) Receive services performed by someone other than Harvest One Limited or authorized dealers.
- (d) Without limiting the foregoing, water damage, sand/corrosion damage, battery leakage, dropping the laser trigger, scratches, abrasions or damage to the body, or damage to the hot shoe or cables, will be presumed to have resulted from misuse, abuse or failure to operate the Laser Trigger as set forth in the operating instructions.

NO IMPLIED WARRANTY, INCLUDING ANY IMPLIED WARRANTY OF MERCHANTABILITY OR FITNESS FOR A PARTICULAR PURPOSE, APPLIES TO THE LASER TRIGGER AFTER THE APPLICABLE PERIOD OF THE EXPRESS LIMITED WARRANTY STATED ABOVE, AND NO OTHER EXPRESS WARRANTY OR GUARANTY, EXCEPT AS MENTIONED ABOVE, GIVEN BY ANY PERSON OR ENTITY WITH

RESPECT TO THE LASER TRIGGER SHALL BIND HARVEST ONE LIMITED. HARVEST ONE LIMITED SHALL NOT BE LIABLE FOR LOSS OF REVENUES OR PROFITS, INCONVENIENCE, EXPENSE FOR SUBSTITUTE EQUIPMENT OR SERVICE, STORAGE CHARGES, LOSS OR CORRUPTION OF DATA OR ANY OTHER SPECIAL, INCIDENTAL OR CONSEQUENTIAL DAMAGES CAUSED BY THE USE OR MISUSE OF, OR INABILITY TO USE, THE LASER TRIGGER, REGARDLESS OF THE LEGAL THEORY ON WHICH THE CLAIM IS BASED, AND EVEN IF HARVEST ONE LIMITED HAS BEEN ADVISED OF THE POSSIBILITY OF SUCH DAMAGES. IN NO EVENT SHALL RECOVERY OF ANY KIND AGAINST HARVEST ONE LIMITED GREATER IN AMOUNT THAN THE PURCHASE PRICE OF THE CACTUS LASER TRIGGER SOLD BY HARVEST ONE LIMITED OR ITS AUTHORIZED DEALERS AND CAUSING THE ALLEGED DAMAGE. WITHOUT LIMITING THE FOREGOING, YOU ASSUME ALL RISK AND LIABILITY FOR LOSS, DAMAGE OR INJURY TO YOU AND YOUR PROPERTY AND TO OTHERS AND THEIR PROPERTY ARISING OUT OF USE OR MISUSE OF, OR INABILITY TO USE, THE CACTUS LASER TRIGGER NOT CAUSED DIRECTLY BY THE NEGLIGENCE OF HARVEST ONE LIMITED. THIS LIMITED WARRANTY SHALL NOT EXTEND TO ANYONE OTHER THAN THE ORIGINAL PURCHASER OF HARVEST ONE LIMITED, OR THE PERSON FOR WHOM IT WAS PURCHASED AS A GIFT, AND STATES YOUR EXCLUSIVE REMEDY.

Corporate Office:

HARVEST ONE LIMITED
11D, BLK 2,
KOOH WAH MIRROR FACTORY (6TH) IND. BLDG.,
7-9 HO TIN ST,
TUEN MUN, HONG KONG

PLEASE CONTACT YOUR LOCAL DEALER FOR CUSTOMER SERVICES.

© HARVEST ONE LTD. 2013 (3rd EDITION)

cactus

www.cactus-image.com