



Lightstream

 **dedolight**®

English 04/19

TABLE OF CONTENT

Chapters

Introduction	Page 3
Reflected Light	Pages 4-6
dedolight Lightstream	Page 7
Lightstream Drama	Page 8, 14-17
Lightstream TV	Page 8, 18-24
Reflectors	Pages 9-11, 42-52
Hard and soft light	Pages 12-13
Virtual light source	Pages 14-15
Multiple reflections	Pages 16-17
Lightstream TV	Pages 18-24
Parallel beam	Pages 25-28
DPBA Parallel beam intensifiers	Pages 29-41
Reflectors, accessories & mounting ...	Pages 42-52
DPB70 Case	Page 51-52
Ian Murray, DOP	Pages 53-67
His view of Lightstream	
Francois Aubry	Pages 68-69
Square law	Page 70-71

Themes

Virtual light source	Pages 5, 14-15
Polarization by reflection	Page 6
Parallel beam	Page 7, 25-28
Lightstream Drama	Page 8
Lightstream TV	Pages 18-24
DPBA Parallel beam intensifiers	Pages 29-41
Reflectors & accessories	Pages 9-11, 42-52
Square law	Page 70-71

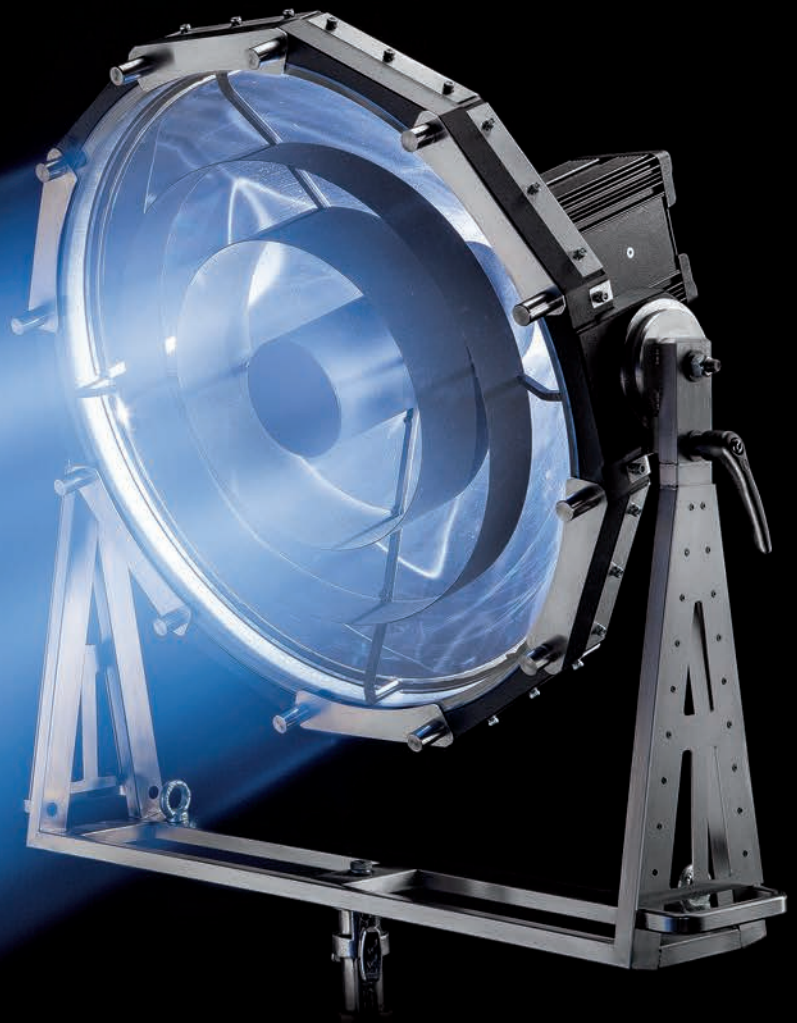

Introduction

The brochure ‚dedolight Lightstream‘ should not be regarded as a general lighting tutorial. Here we will mainly concentrate on various aspects of reflected light.

We are well aware that light and lighting is a vast subject with an incredible variety of aspects about the character of light. There is unnoticeable natural light, there is unnoticeably created light.

There is unnoticeable light with subtle accents, guiding the attention.

Such lighting can serve as an element of image composition.

Then we have the many characters of noticeable lighting, as gentle as the autumn light in Paris,

which makes women all look like they have been painted by Renoir.

All the way from this wonderful, gentle, amiable light character that makes people glow, to the dramatic light characters as you find them in Caravaggio and El Greco.

Yes, we all know that lighting and the art of lighting should not be regarded as a value on its own. The most important is the story that we need to tell and what style we choose. And from this vast field of many subjects, here we are mainly talking about aspects of reflected light in its purity, and mixed with other lighting instruments and characters. Here we want to talk about the tools, the physics and practices; and hopefully we will be able to give some valuable explanations and hints.

REFLECTED LIGHT

Everyone of us has used reflected light in our profession, be it cinematography or other approaches to image creation.

Reflected light can provide a multitude of characters, many of which are not achievable by any method of direct lighting.

Hard reflection can have a very special character. Sometimes, this could be interpreted as simply redirecting the light, where, at the same time we are creating a virtual light source at considerable distance from the object being lit.

Hard reflected light very often is also polarized light, providing a different surface texture, different impressions. Gentler reflections can show a great variety of spreading of the reflected light. In all of these, it is important to consider the area, from which the light is being reflected. Small area reflections may still provide harder light and harder shadows. Larger reflective areas will produce gentler transitions between light and shadow.

Reflective surfaces vary in the degree of reflectivity: All together reflective surfaces provide a rich choice and an incredible variety of influencers for the character of light used.

Colored reflective surfaces may add qualities of their own in an incredible variety from the shiny gold reflector, used to produce warm and pleasant skin tones, to warm-colored wooden surfaces, adding subtle hues of warmth to the image and skin tones.



photo from Sylwester Adamski, Poland



photo from Sylwester Adamski, Poland

In combination with narrow-beam light fixtures or parallel beam light fixtures it is possible to transport tremendous intensity of light over a considerable distance.

Combining such light fixtures with the use of reflective surfaces can be used to redirect light, but can also be used in many different ways, and can add to an incredible variety of creative tools and practices.

KNOWN METHODS AND PRACTICES

Example 1:

To light interiors of a high building, beam projectors are placed on street level, shining straight up. Large, hard reflectors placed overhead of the windows redirect the incoming light and simulate incoming natural daylight. Because we create a **virtual light source** way up and high in the sky.

We add the distance from the light fixture to the reflector, and add distance of a **virtual light source** way behind of such a parallel beam light fixture. The effect is a light that is placed very far away, thus minimizing the effect of the inverse square law. It allows actors to move freely, without any noticeable change of light intensity and creates a “natural” light.



photo from Sylwester Adamski, Poland: Lighting of a film set in Warsaw



photo from Sylwester Adamski, Poland: HELIOGRAF's night shooting

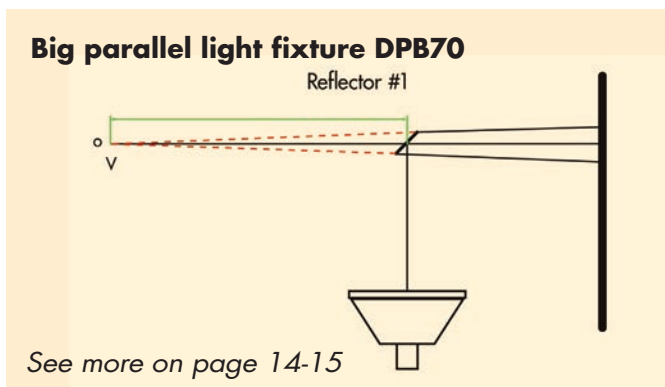

with classic dedolight (DLH4) in spot position virtual light source is 100 cm behind the light

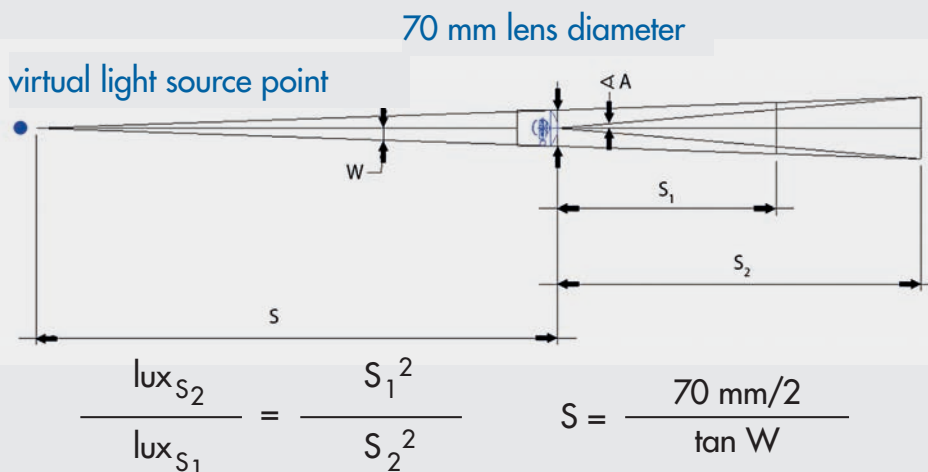

Since the special optical system of the dedolight allows for a very narrow exit angle, down to 4°, the virtual light source results from the elongation of the outer rays, and where those cross, the virtual light source becomes active.

Example 2 (Dedo Weigert):

On a film that I shot in the early 1970s in Indonesia, I had to film inside large housings which had rooftops, reaching very far down.

Since in such large (communal) housings the people live on a raised platform, I was able to acquire a considerable number of table-tops, which I fitted with broomsticks on a hinge. I covered these table-tops with a very lightweight reflective material from Rosco (Rosco Flex). There was even a special glue to attach such a reflective material to pretty much any surface (Rosco Bond). Thus, I was able to create with a small budget an efficient multitude of very hard mirror-like reflectors and many other reflectors with a crumpled surface, producing a more dispersed reflection, softer and gentler light that would spread wider.

Placing these table tops at angles all around the building, I was able to reflect the sunlight towards the interior ceiling.

In addition, I covered these interior ceilings with more of such reflective lightweight materials, thus reflecting the reflected light into a very gentle but still controlled and variable way onto the action area in the center of the living spaces.

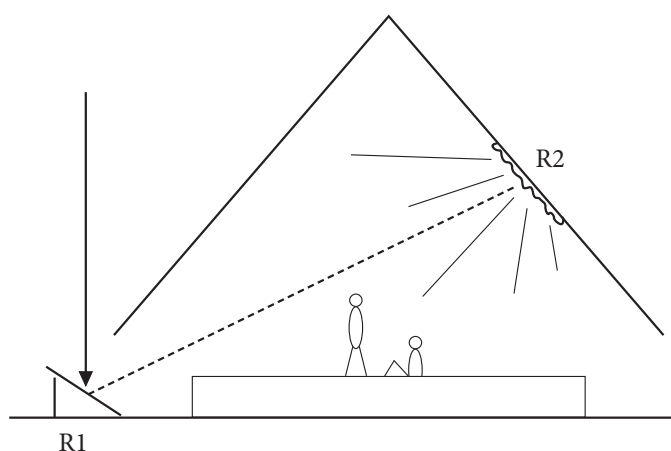

That worked very well. It was simply necessary that my assistant would step out every once and again to re-direct the reflectors as the sun was moving, but since near the equator the sun is friendly enough to stay for a long time very high up in the sky, the re-adjustment was easy and quickly done.

Example 3 (Ian Murray):

In one of our tutorial videos, the British DOP Ian Murray shows how a hard reflected light becomes polarized, and he holds up his hand and shows how the impression and the narrative of the skin on the surface of his hand is changed by the polarized light, generated by the hard reflective surface.

Everyone of us can add a variety of other examples, including the common practice of using bounce-boards, bead-boards, styrofoam surfaces and such.



Direct light - photo by Ian Murray

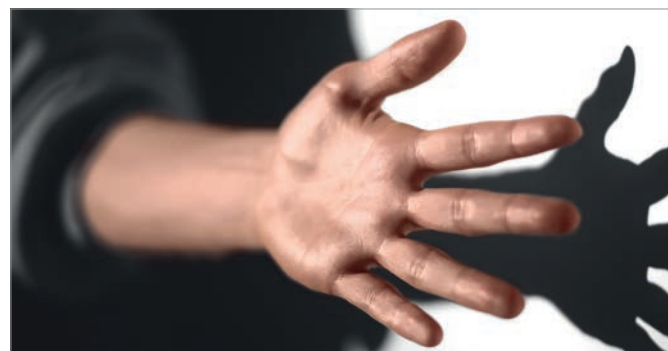

Reflected light - photo by Ian Murray

Find on **YouTube**

Shining light through glass



DEDOLIGHT® LIGHTSTREAM

In general, reflecting light is a well-known and established practice in image creation and for special effects, but with dedolight Lightstream system it attains perfection, making it uniquely suitable for new and revolutionary lighting practice.

Historically, reflected light systems have been used in feature films in great purity*.

dedolight Lightstream Fixtures

PARABOLIC LIGHT FIXTURE

Currently among our dedolight Lightstream tools, the most powerful single-purpose light is the DPB70, a high-efficiency parabolic light head, producing a near parallel beam (70cm diameter).

Other parabolic parallel beam lights are known throughout the professional industry, but users find that our DPB70 parallel beam light excels in extreme efficiency and unprecedented homogeneity within the beam, which is a prerequisite for the dedolight Lightstream lighting system.

See comments by Adam Chambers, gaffer for DOP Hoyte van Hoytema on the movie 'Ad Astra' (James Gray).



PARALLEL BEAM INTENSIFIERS

Another important group of our exquisite tools is based on the 21 different dedolight focusing lights, now with the miraculous, unprecedented parallel beam intensifiers.

The optical concept of the dedolight focusing lights already shows unprecedented performance in the spot position, 300% in comparison to the functionality of traditional studio Fresnel lights.

The optics were awarded twice by the Oscar Committee of the Academy of Motion Picture Arts and Sciences, and with an Emmy.

The complete range of parallel beam intensifiers represents a computer-correlated design, matching these unique dedolight optics. Now available for each and every one of our 21 focusing lights.

Increase of light output over the already astounding spot performance of the original light, ranges from 2 times to 5 times over the intensity achieved in the spot position of the focusing light.

REFLECTORS

The dedolight Lightstream system comprises a selection of highly efficient reflectors with different surfaces and different functions, providing a wide choice of lighting tools and characters.

Such unique reflectors are available in sizes from 1x1m to 50x50cm, to 25x25cm, even down to small ones with 7x10cm. We are developing further sizes and functions.

*For example, by the Austrian DOP Christian Berger and his experienced gaffer Jakob Ballinger in films by the Austrian director Michael Haneke, as well as in the Brad Pitt and Angelina Jolie film 'By the Sea'.

Applications

dedolight Lightstream Drama

Such systems usually include the big parallel beam light DPB70, possibly augmented by other focusing dedolights with the unique parallel beam intensifiers. Such lighting practice can provide a feeling, character and function of natural light by the characteristics of the parallel beam lighting. The effect is not based on the distance between the light fixture and the object, but works effectively like a virtual light source, coming from an enormous distance, thus allowing a more natural character of lighting on a set, on a person, on a subject, at the same time eliminating a lot of lighting paraphernalia, stands, flags and other devices which usually clutter such sets.

The dedolight Lightstream system can provide structured lighting, giving the illusion of depth and space.

dedolight Lightstream TV

The transformation of dedolight Lightstream for application in TV studios, where our focusing lights in conjunction with the amazing parallel beam intensifiers can serve a multitude of reflectors efficiently. These can redirect the light in many different directions. They can also be placed in a linear row.

The complete television lighting Lightstream system can prelight different positions of actors, presenters or objects, without the need of readjustment and resetting the tools.

Here we achieve an extreme degree of efficiency, unique in lighting practice for TV studios.

We have produced a video, demonstrating a studio simulation, where with a mere 790W we achieve lighting with lux values comparable to studio lighting previously done with 30kW or more.

The DPB70 parabolic light and the dedolight Lightstream system are presently employed in 2 US TV series –

The Resident- Season 2 premieres Sept 24 2018.

Cinematographer:

John Brawley - here is his imdb:



The Resident imdb page:



Magnum P.I.- Season 2 premieres Sept 24 2018
imdb page:



CHOICE OF REFLECTORS

Reflector surfaces

These are reflectors for the application and use in dedolight Lightstream Drama and dedolight Lightstream TV.

The high efficiency of these reflectors within this system derives from reflective values, where approx. 95-98% of the light can be effectively reflected.

At the moment we use four different reflector types, each featuring a different reflecting surfaces.

Reflector #1

is the closest to a very hard reflector, but it is not a mirror. A fully functional mirror usually would not work well for this kind of lighting system, it would not redirect the incoming light, the beam with sufficient homogeneity.

reflector #1 serves the purpose of **redirecting** the light without changing the beam size and the beam character. The attempt here is to cause a minimum of stray light and a minimum of diffusion. This surface structure provides reflection with an exit angle of about 4°.

The enclosed measurements were done with a DLH400DT metal halide light with the small parallel beam intensifier (DPBA14), using reflectors 25x25cm.

Reflector	Lux 1m	Lux 2m	Lux 3m	Lux 4m	Lux 5m
No.1	49500	26000	16100	10000	6700
No.2	29000	10700	5800	2700	1930
No.3	12200	3400	1630	890	550
No.4	1890	490	215	125	85
Styrofoam	2000	520	230	132	92

For comparison purposes we have included a styrofoam surface.

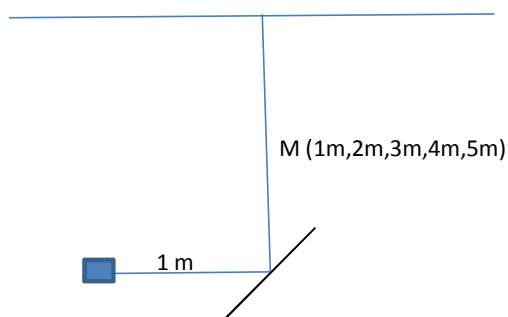

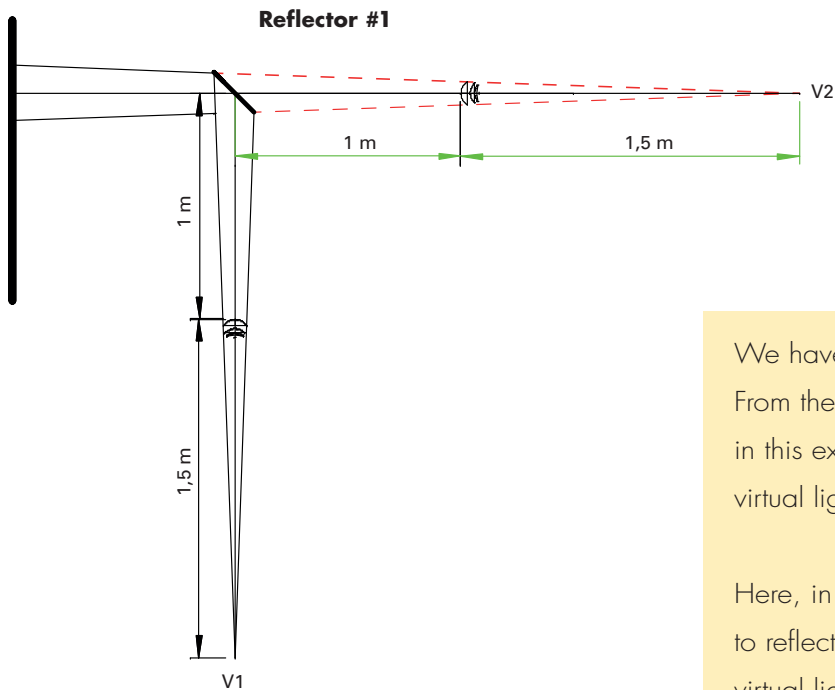

Reflector #1

As you can see (in the table page 9) reflector #1 has the highest intensity of reflecting light when measuring in the center of the reflected light

We have explained the term 'virtual light source'.* From the graphics you can see that the light used in this example with reflector #1 will provide a virtual light source behind the reflector.

Here, in this example the distance from light fixture to reflector is 1 meter and the distance from the virtual light source to light fixture is 1.5 meter. therefore the virtual light source behind the reflector would be at $1\text{ m} + 1.5\text{ m} = 2.5\text{ m}$.

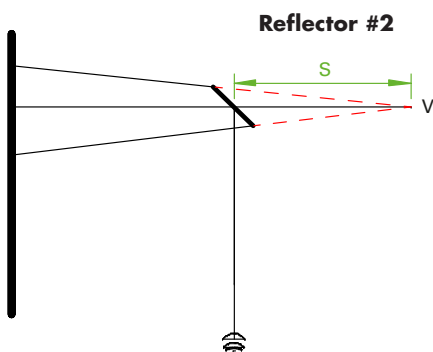

Reflector #2

Reflector #2

shows less light intensity at the object, although the total amount of reflected light remains pretty much identical with 95-98%, but due to the wider exit angle of 12° , it makes it more suitable when we want to arrive in the next reflection from the secondary reflector with a larger surface.

Here we can see that the virtual light source now is much closer to the reflector. We would now have to assume in the example given, that the virtual light source is only at a distance of 47cm.

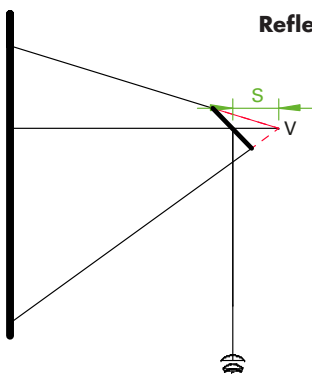

Reflector #3

Reflector #3

It appears to be much gentler, although again the same amount of light gets reflected, but spread over an angle of 50° .

* see pages 5, 14 and 15

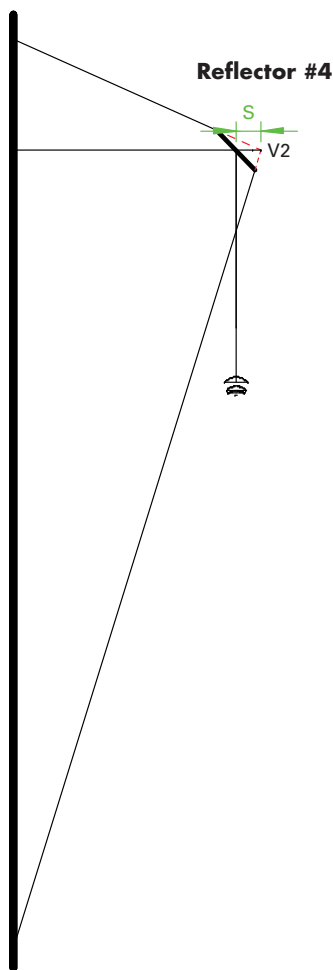

Reflector #4

which produces seemingly the most gentle reflection, covers an angle of 95° , and thus, lower values of light level reaching the object, and the virtual light source now, coming very close to the reflector surface, only 6 cm behind the reflector.

When comparing Lightstream reflector #4 with the commonly used styrofoam, we have comparable values of light intensity reaching the object. Thus, we now have to assume that the theory and practical function of the virtual light source, as generated by reflector type #1, may drastically change the influence of the square law, minimizing the differences in exposure value, when our talent is moving.

This effect is minimized when we use reflectors #3 and #4, or a styrofoam.

Here we are closer to the assumption that the reflector surface itself becomes a light source, and therefore the consideration regarding the effect of the square law is now with the reflector surface as the light source*.

* more information see page 12

The actual size of the reflector in relation to the distance to the lit object determines the perception of hard and soft light* - the light and shadow transitions.

* more see page 12

IV - HARD AND SOFT LIGHT – DIRECT OR REFLECTED

Here we are talking about two different aspects.

On the one hand, the characteristics of the different reflector surfaces play an important role between the hard, narrow exit angle from reflector #1, which I prefer to call the one to ,re-direct' light, whilst #2, #3 and #4 I call reflectors, because they have a larger exit angle.

The effect of the light, reflected from reflector #1 is hard and selective, it does not change the incoming beam character. It is merely re-directing it.

This reflector can easily be confused with known mirror reflectors. Mirror reflectors don't have the same characteristics, they indeed sometimes produce spotty and uneven light, whilst our reflector #1 re-directs the light without changing its character, without changing much on the beam angle.

Whilst the reflected light from reflector #4 exits in a very wide angle and covers an enormous area, and therefore sometimes is hardly noticeable, it is an ideal tool as a base light and for ambient light.

Again, we have to point out that there is often a misunderstanding, where reflectors with a narrow angle of exit, like #1, are seen as hard reflectors; and it appears to the eye and the camera that a lot of light is reflected, whilst reflectors that have a large exit angle and cover a huge area, are often seen as reflectors that reflect less light and therefore are perceived as softer and gentler, but may still produce identical light and shadow transitions.

In effect, all these reflectors have in common a very high degree of reflectivity (above 95%) but that the reflectors which appear softer and gentler, simply spread the light over a wider area.

On the other hand, it has to be noted and taken into consideration that the surface area of a reflector that is actually used by the incoming light defines the character modification between hard light and soft light. Even if we take a reflector with a large exit angle, like #3 with 50 degree exit angle, and light only a small part of such a reflector, it will appear as a hard light, and shadow edges will be relatively hard.

If the entire surface area of a larger-sized reflector is lit by incoming light, it will have more the effect of a soft light.

Sometimes, for some of us it is difficult to understand that the seemingly gentler reflector which produces the very large exit angle, like reflector #4, appears to be soft, simply because it is reflecting less light as noticed by the eye of the viewer. But for the characteristics of a soft light it is exclusively the size of the area of light emission, in relation to the distance to the object.

If we have a large area reflecting light, and an object close by, this will be practically shadowless light, or if there is any shadow noticeable, the transition between light and shadow will be a fluent, transparent transition, whilst if the same size of area of light emission is further away, the impression will be that this is a harder light, and it will produce harder shadow edges.

To give an extreme example –

The sun has a huge diameter, but is very far away, thus the huge area of light emission from the sun, by the time it reaches us, will produce very hard shadows; whilst the other way round, a huge surface soft light, like we have with our Panaura5 and Panaura7, when the front diffuser is lit all the way to the edges, defeats the function of the square law.

So shadow transitions are very smooth, if the object is close to the front diffuser or area of light emission.

When thinking about reflected light, we don't necessarily have to think of size and character of a reflector as described in this brochure. We can think of the table cloth on the dinner table, the floor, the ceiling, the wall of a room, as a soft light source.



VIRTUAL LIGHT SOURCE, CREATING THE ILLUSION OF NATURAL LIGHT *

Example -

We have explained that the virtual light source, shown here as V1 is way behind the actual light fixture, if it is a parallel beam light or something near parallel beam. The distance of the light fixture to the virtual light source V1 is to be calculated by elongating the rays at the edge of the narrow beam, here assumed at 2 degree, for the DPB70. And V1 will result where those rays meet – at 20 meter distance in the back of the light fixture.

When we consider a true parallel light exit, it would be understandable that V1 would be at an even much farther distance – theoretically infinity.

The DPB70 is NOT a focusing light fixture. When changing the lamp it may be desirable to make minimal adjustments of the lamp in the longitudinal axis, to achieve optimum homogeneity of the beam. Close to the light exit you may detect a darker center, because in our design the direct forward light from the lamp is blocked. Best homogeneity starts at 3 meters and should be measured at 5 meters, or further distances.

2 - When using reflector #1, in this example assumed as a 3x3ft reflector (100x100cm), we can redirect the maximum of incoming light, even at a considerable distance. Reflector #1 is not a true mirror, but very close to the effect of an assumed perfect mirror.

It would be extremely difficult and exorbitantly expensive to create such a perfectly flat mirror, thus, many reflectors that look like a mirror at first sight,

reflect incoming light in a way that shows spots and uneven light distribution, because optically they are not perfectly flat.

This is why we use our reflector structure #1, which comes closest in practical life to the function of redirecting the light without changing the beam character

3 - With reflectors #2, #3 and #4, which have a different surface structure, the same effect cannot be reached, and with those, as explained previously, the virtual light source would appear to be much closer to the back of the reflectors, so that it could not have the same effect of redirecting the light, and thus not producing the impression of natural light.

4 - V2, the assumed virtual light source, in this example is very far away, adding the distance from the light fixture to V1, to the actual physical distance between the light fixture and the reflector.

5 - The effect of the redirected light simulates natural light. This effect and this impression is not achievable with most other methods of simulating incoming sunlight. If several powerful lights are placed outside windows to simulate incoming light, very often they create diverging shadows or the effect of non-parallel light

With Lightstream and near parallel beam, we achieve the feeling of natural light.

*see image on page 15

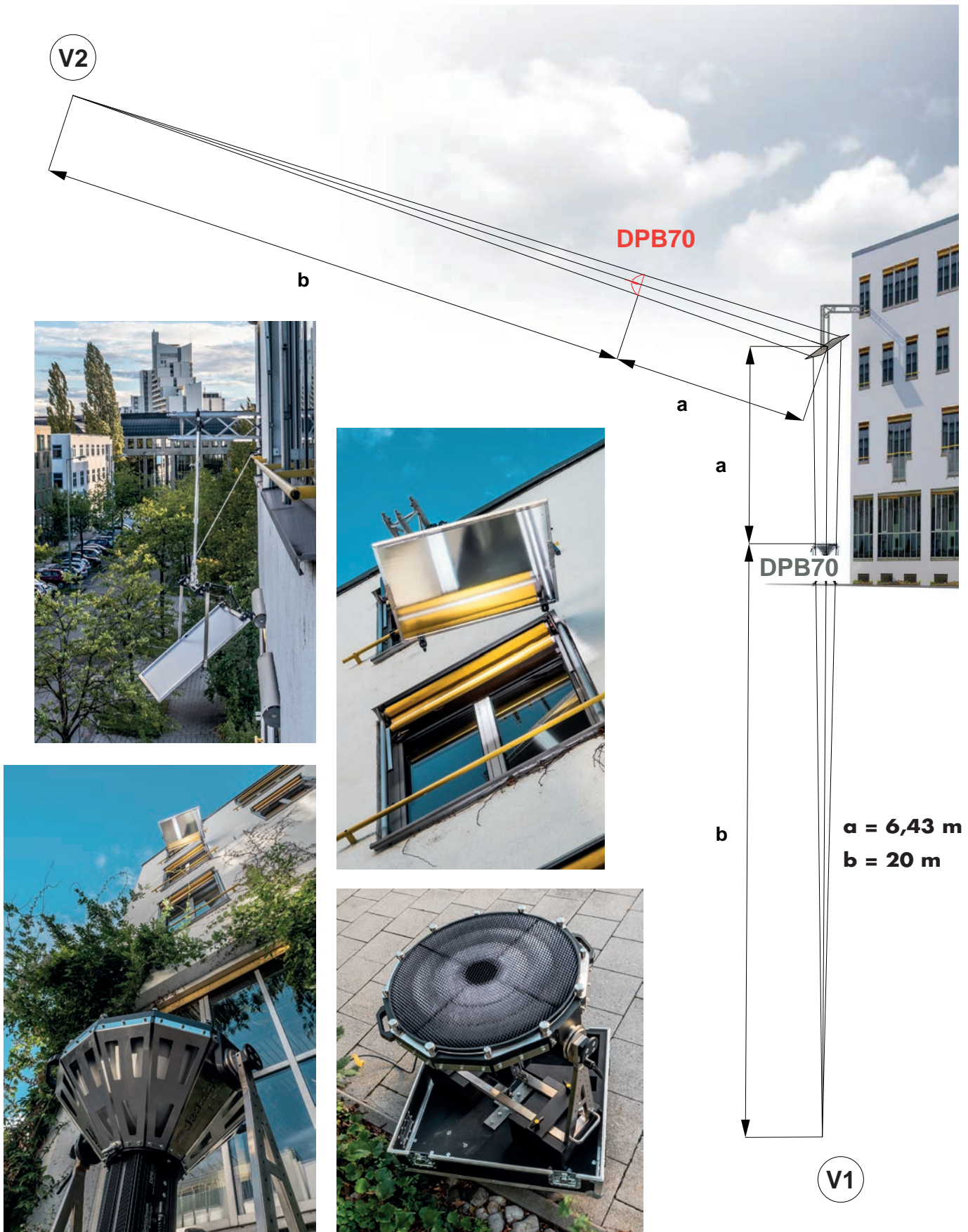

EXAMPLE OF USING MULTIPLE REFLECTORS CONSECUTIVELY

Example

The image shows the light coming from the parallel beam projector DPB70, shining onto the hard, big 3x3ft (100x100cm) reflector R1, which is redirecting the light. Redirecting the light does not change the character, nor does it influence much the beam angle of the redirected light.

The redirected light now is used by reflector #R2, which could be a reflector #2, relatively hard, changing the direction of the light towards R4, which would be a softer, gentler reflector, possibly surface #3 or surface #4, spreading the angle of exit, thus, acting as a gentler fill light on the person behind the desk, whilst reflector R3 could be surface #2 or #3, reflecting the light onto the person, possibly acting as a key light.

It might be mentioned that when reflector R1 is placed in an ideal position, redirecting the light coming up from street level, it should possibly be placed in such a way that the view out of the window may remain totally unhindered, adding further possibilities in the creation of a natural light simulation.

Re-reflecting the light several times allows to reach different areas of the set. This makes it possible from a single light source, to have the effect of lighting coming from many different directions.

Being able to vary the depth of insertion of the reflectors, deeper or less deep into the narrow redirected beam of the reflected light, works like an opto-mechanical dimming, where only as much light can be used by the reflector, reaching into the beam as it takes out of the beam, depending on the surface that is hit by the incoming light, and thus, it brings with it a very elegant and convincing method of influencing the amount of light to be used.

As mentioned previously, the effect of harder or softer light is not directly dependent on the angle of light exit from the reflector, but mainly by the surface area of the reflector used. The larger the area used on the reflector is, the softer, the gentler the function of the light, and the shadow edges will appear gentler and more with a soft transition when a larger area of a reflector is used.

This is often confused with the amount of light, but then again the perception of a soft light, as depicted in the final image, is dependent on the size of the actual light-emitting area.

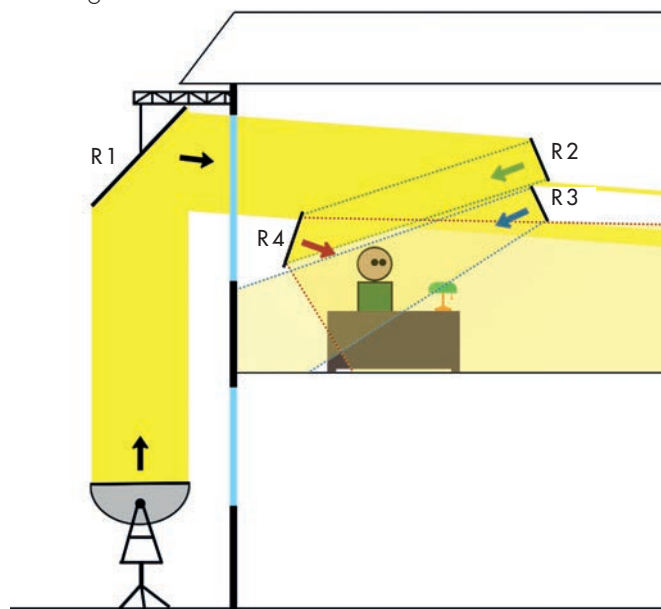

This system's explanation refers to the basic setup as we have shown in the video.

Find on **YouTube**



Here again we see the big 1200W parallel beam light placed at street level, shining into a 100x100cm reflector #1, which redirects the light to the window on the second floor.

This of course can be done in such a way that the view out of the window is perfectly unhindered.

This redirected light then is split into 2 further reflectors 50x50cm, where the upper one re-reflects the light towards the reflector, providing the fill light, whilst the lower one provides the direct key light on the person behind the desk.

In the example on this page, we see a DLED7 focusing LED dedolight 90W, combined with a parallel beam intensifier, shining straight upward onto the reflector #1, which redirects the light onto reflector #2, where you can see, that here the light is already being spread with a larger exit angle, now reflecting the light onto the third reflector, which could even be the reflector #3, providing from its entirety of the surface a gentle soft light with lower intensity because of its large spread angle.

The next picture shows the same situation, where the focusing dedolight LED light is now replaced with a laser pointer, shining up onto reflector #1, where we can see the laser beam is redirected with very little change of its character onto a reflector #2, which shows a reflection in a much wider angle, pretty much filling reflector #3 at the bottom of the picture for gentler light reflection.

All these examples show how the light character can be influenced by the reflector surfaces, and of course the light- and shadow-shaping of the reflectors does not only depend on the structure on the surface of the reflector, but always on the size of the reflector in relation to the distance of such a reflector to the lit object.



DLED7 + DBPA



Outlining change of area covered (angle).

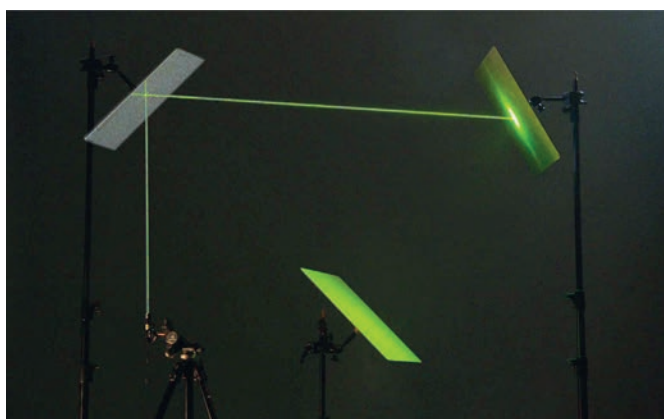

Using a laser pointer to shine up onto reflector #1 we can see that the laser beam is redirected with very little change of character. Reflector #2 already shows in its reflected light a wider angle, pretty much the entire surface area of reflector #3 on the bottom for gentle light.

LIGHTSTREAM TV

Introduction -

Although Lightstream technology and other practices of lighting with reflected light, were originally intended for major drama productions only and have proven to be very successful in this field, we have, with our more highly developed technology, expanded these practices for the lighting of television studios.

Here we are using our parallel beam intensifiers and parallel beam lights with our reflector system, not exclusively, but also in combination with other dedolight light fixtures, to provide a choice and variation of character.

For the lighting of television studios, Lightstream TV offers unprecedented economy in light efficiency and energy consumption and fixture inventory while extending creative possibilities. It also offers a very interesting choice of easy and quickly installed lighting, which can be set for different positions of persons or sets to be lit, and it is also eminently suitable for multi-camera work.

Many different lighting situations can be preset and prepared with great ease, and can be lit simultaneously, or

chosen by simple changes of the control on the DMX boards or other remote control systems.

In the following pages, we are explaining lighting systems and simulations, not actually showing television studios being lit, but simply trying to give an explanation of the instruments and tools, which can be used for such lighting practice. Also proving the functionality of the system.

Expanded choice of tools -

In addition to our parallel beam light fixtures and the tremendous choice of super effective parallel beam intensifiers, we have now also added motorized reflectors, which can be controlled by cable and DMX, and in future also by wireless control, adding to the ease of changes of lighting setups, if it is not practical to pre-light many different lighting situations from the beginning (which is also possible with these tools in very simple practice).

The Resident
imdb page:



Magnum P.I - Season 2
imdb page:

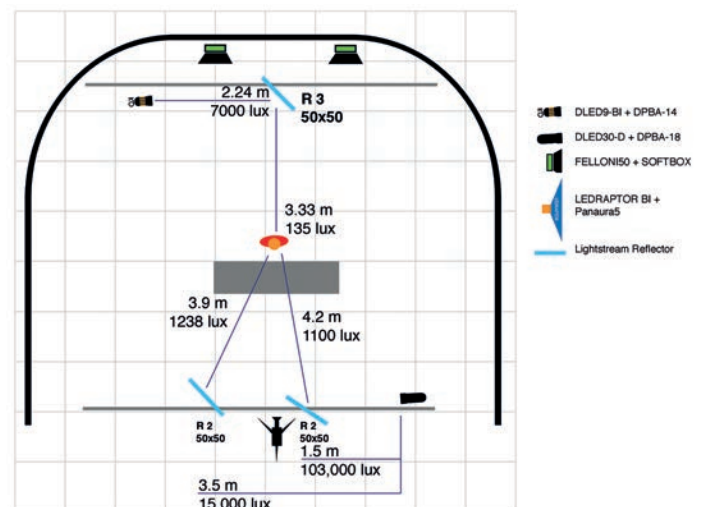
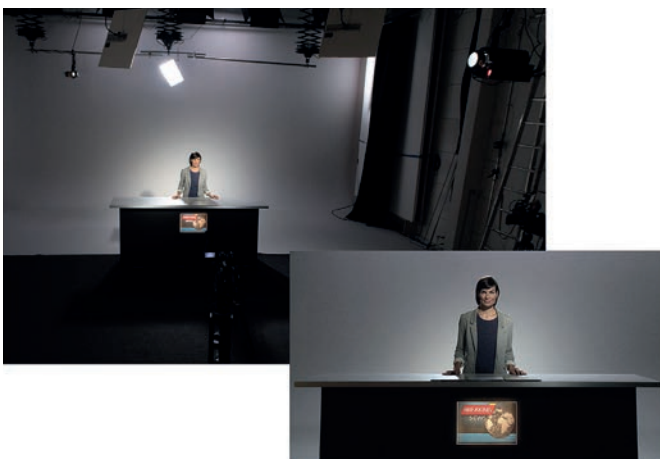

In the photo bottom left, we see that the frontal lighting is done with one DLED30-D (300 W) with DPBA-L18 parallel beam intensifier and two reflectors 50x50cm.

The distance from the light fixture to the first reflector is 1.5m, to the second reflector 3.5m.

The lux values on the person, measured in front, can be set at 1200 lux and 1100 lux, at a distance between 3.9 and 4.2 meters.

In the back we have light shining in the other direction, a DLED9 bicolor fixture (2 x 90 W) with parallel beam intensifier DPBA-14 onto a single reflector 50x50cm, providing a back light of 135 lux.

Further in the background, pointing downward, are 2 Felloni standard lights 50° with soft box.

In the long shots of these pictures you will see several other lighting fixtures on the ceiling, which happen to be in the studio. We left them, but they were turned off.

In the photo bottom right, the setup is similar to the one described above, except that this time the DLED9, 90W LED light is lighting 2 separate reflectors to give more sculpturing to the person from the back lights.

Now we have 250 looks of both back light reflectors.

In the background you also see a gobo projection which is easily interchangeable.



Lighting a single person / announcer
with 2 back lights

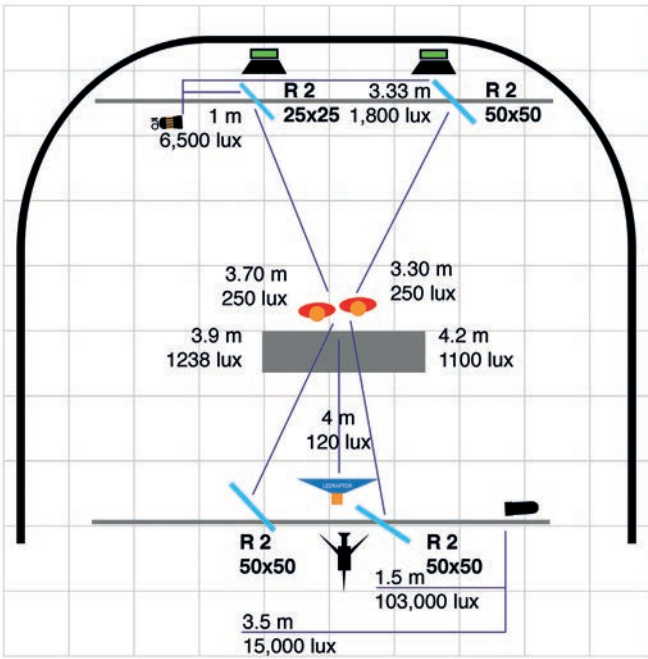
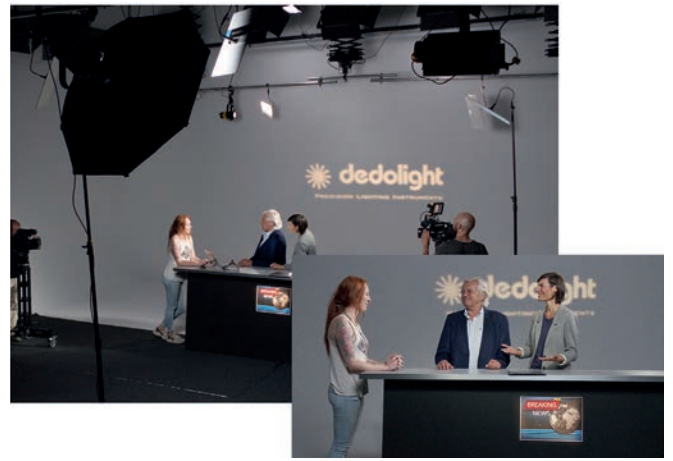

- DLED9-BI + DPBA-14
- DLED30-D + DPBA-18
- FELLONI50 + SOFTBOX
- LEDRAPTOR BI + Panaura5
- Lightstream Reflector

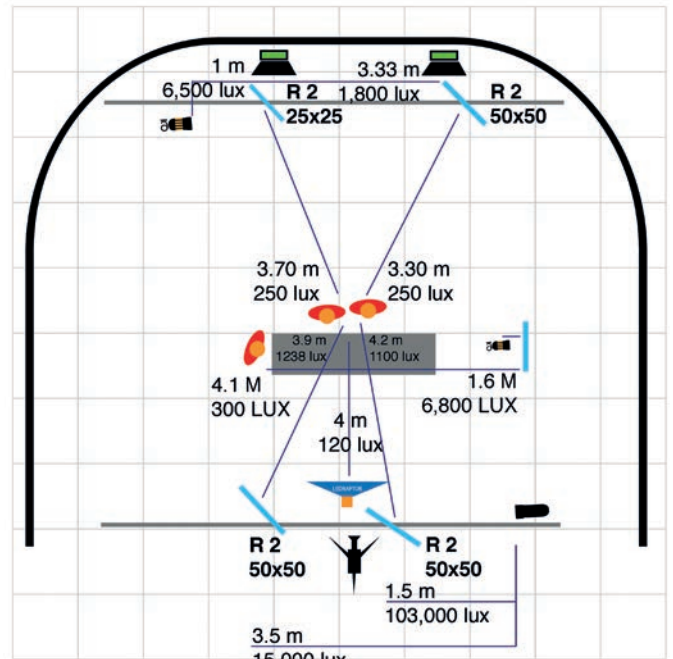

- DLED4-BI + DPBA
- DLED9-BI + DPBA-14
- DLED30-D + DPBA-18
- FELLONI50 + SOFTBOX
- LEDRAPTOR BI + Panaura5
- Lightstream Reflector

Same news room simulation with 2 people, but this time with the addition of a tunable Ledraptor dedolight soft light in bicolor version with 1.5m diameter of the diffuser. Allowing fine-tuning of a gentler lighting approach. Mixing structured reflected light and dedolight soft light. Adding the option of warmer hues (bicolor) or cooler look.

Same news room simulation with 3 people, adding one extra dedolight and a reflector for the third person.

Example of a challenging task for Lightstream TV

Several years ago, we lit 3 new studios in record time. From the beginning to going on the air, everything was achieved for all three studios within four working days.

We did not use the Lightstream TV reflected light system exclusively. We used it in combination with several other dedolight lighting instruments. In this case, the difficulty was that an entire side of the studios is a window, looking out to a full daylight situation (the open sea). In addition, we had to take care of varying positions (directions) of the anchorman and his guests, and had to take care of the varying lighting situations of the exterior background, from full sunlight to night.

We didn't have much time to document all of this, but here is a first video, explaining what was done and how it was done under the following link.

Find on **YouTube**



Lightstream TV system advantages

For the lighting of television studios, the Lightstream approach offers very attractive solutions. For some of these installations we have not applied the reflected light practice with total exclusivity, we mixed it intelligently with other light fixtures and solutions from our LED range. Still, the overwhelming majority of lighting was created by the Lightstream reflected light system.

• Perception of gentleness

The impression of the talent being lit is described as very pleasant and gentle, as opposed to many of the traditional direct light sources, even when fitted with diffusion material, and also in comparison to many multi-LED light sources lighting the talent directly.

The gentleness of the light, arriving at the talent from the reflector, is appreciated without compromising the light quality and the light character.

• Incredible savings of energy

Although in some countries the 'green approach' still doesn't seem to play a major role, the effect of savings of energy with our reflected light system supercedes the already well-known savings that can be achieved by switching from halogen light to LED light.

- Our already efficient parallel beam lighting system, combined with careful use of different reflector surfaces, achieves maximum efficiency. At the same time, it provides a very tunable light character which is perceived as very pleasant.

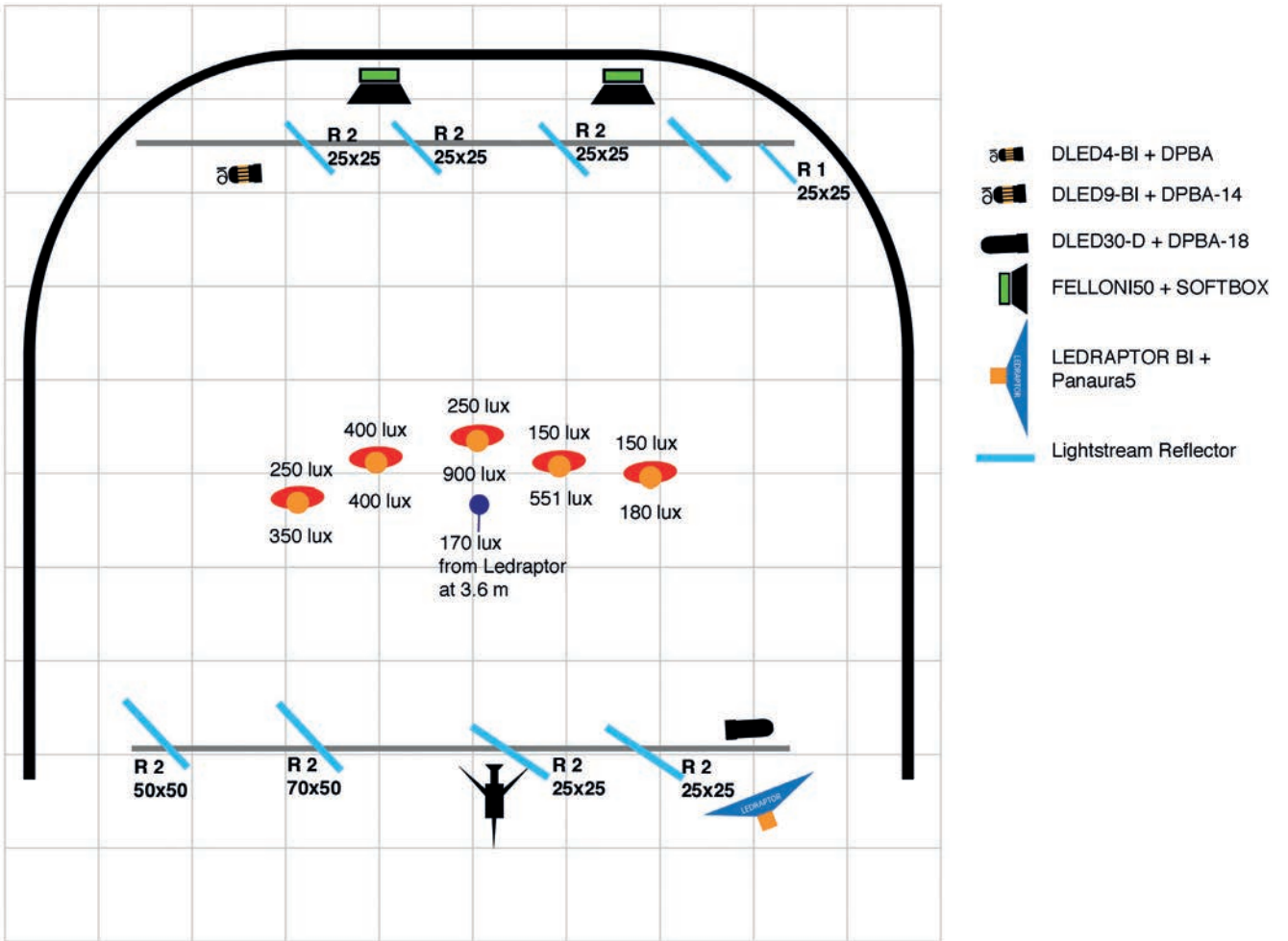

The setup on the previous page, lighting the talk group is quite interesting, since all the lighting on the people is achieved with only 2 LED light fixtures. The DLED30D (the 300W dedolight LED light) fitted with parallel beam intensifier DPBA-L18, lighting from right to left four different reflectors in a row. In the background a single 90W DLED9-BI with parallel beam intensifier (DPBA-14) lights five reflectors (again in a row) for the back light.

For lighting of the background you see 2 Felloni lights with soft boxes pointed downward.

A dedolight LED Ledraptor soft light was gently filling in like melting together in a very subtle way the effects of the reflectors.

The individual people show front light between 180 to 900 lux and back light values between 150 and 400 lux. The Ledraptor adds 170 lux from a distance of 3.6m.

The back wall shows lighting with 2x DLED7 light fixtures, directed at Effect background effect reflectors for the irregular spotty, and to some extent color-changeable background.

You can see a dedolight logo projected on the back wall from a DLED7 light with DP1.1 projection attachment.

By simple control of one light in front, the DLED30-D, shining at four reflectors, and the DLED9, 90W light shining at the five reflectors from the back, a total change of mood and lighting effect can be achieved. From moody silhouette lighting to more gentle lighting. Balancing between the reflected lights and the Ledraptor soft light further allows the choice of gentler or more dramatic lighting situations, just by moving one single slider on the control panel.

All of these simulations are just meant to show the potential of using reflected light for TV studios with great efficiency and very interesting creative potential, perfectly suitable for multi-camera shooting.

This is just a presentation of our system's approach which can be modified and tuned for many different styles, moods, and situations in television studios.



Ledraptor 5: 1,5 m Ø Softlight, tunable color temperature



- **No heat**

It is expected from LED fixtures that they emit very little ‚forward heat‘. In the reflected light system the perceived heat is even less, mainly due to the gentleness of the light character achieved.

- **Versatility**

The Lightstream reflected light system enables to easily light several positions equally and simultaneously in news studios or talkshows when the talents and guests may change places, (as long as these places are pre-identified) without the need to re-light.

We cannot only light for different pre-planned situations, but we can also adjust on the fly.

- **Multitasking**

With one light source and the use of several first stage reflectors and re-reflectors it is possible to light a studio with a minimum number of light fixtures and effortless installation. We have a video of the 3 studios which were installed successfully. (see QR code page 21)

- We are creating additional tutorial videos explaining the practice, the use and the effect of reflective light in television studios, including the light level efficiency, as well as the variations in light character.

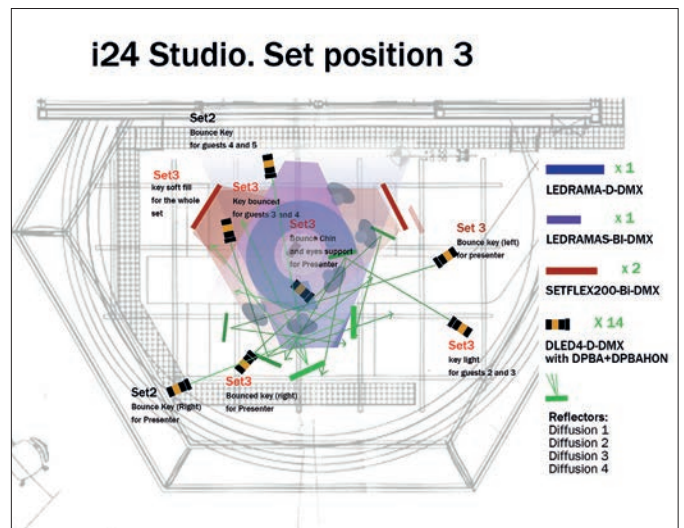
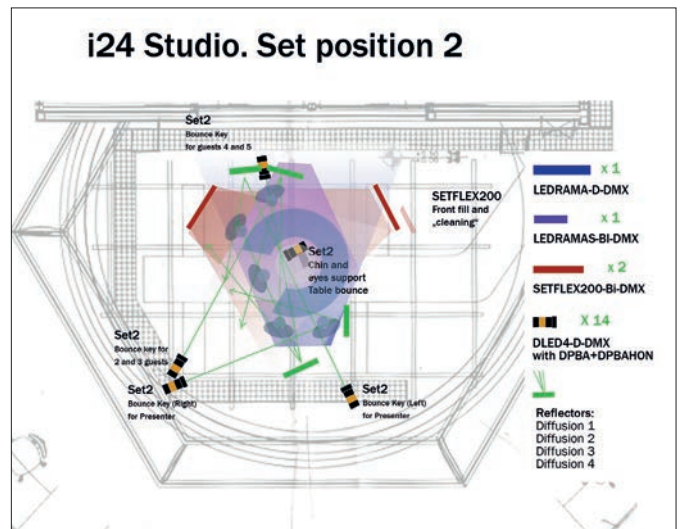
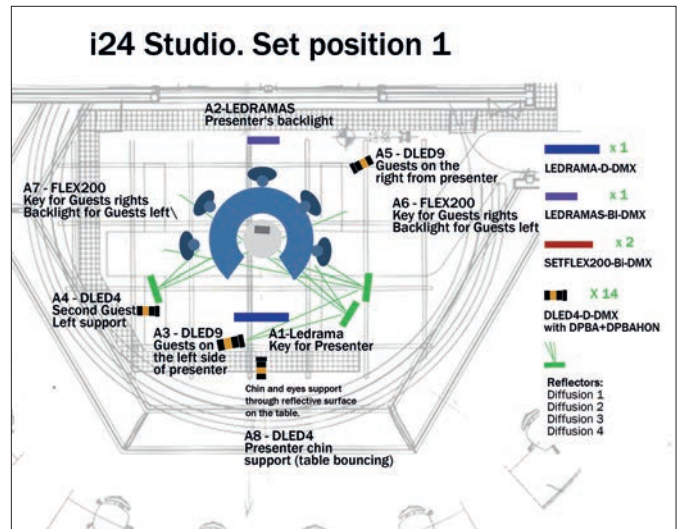

PARALLEL BEAM

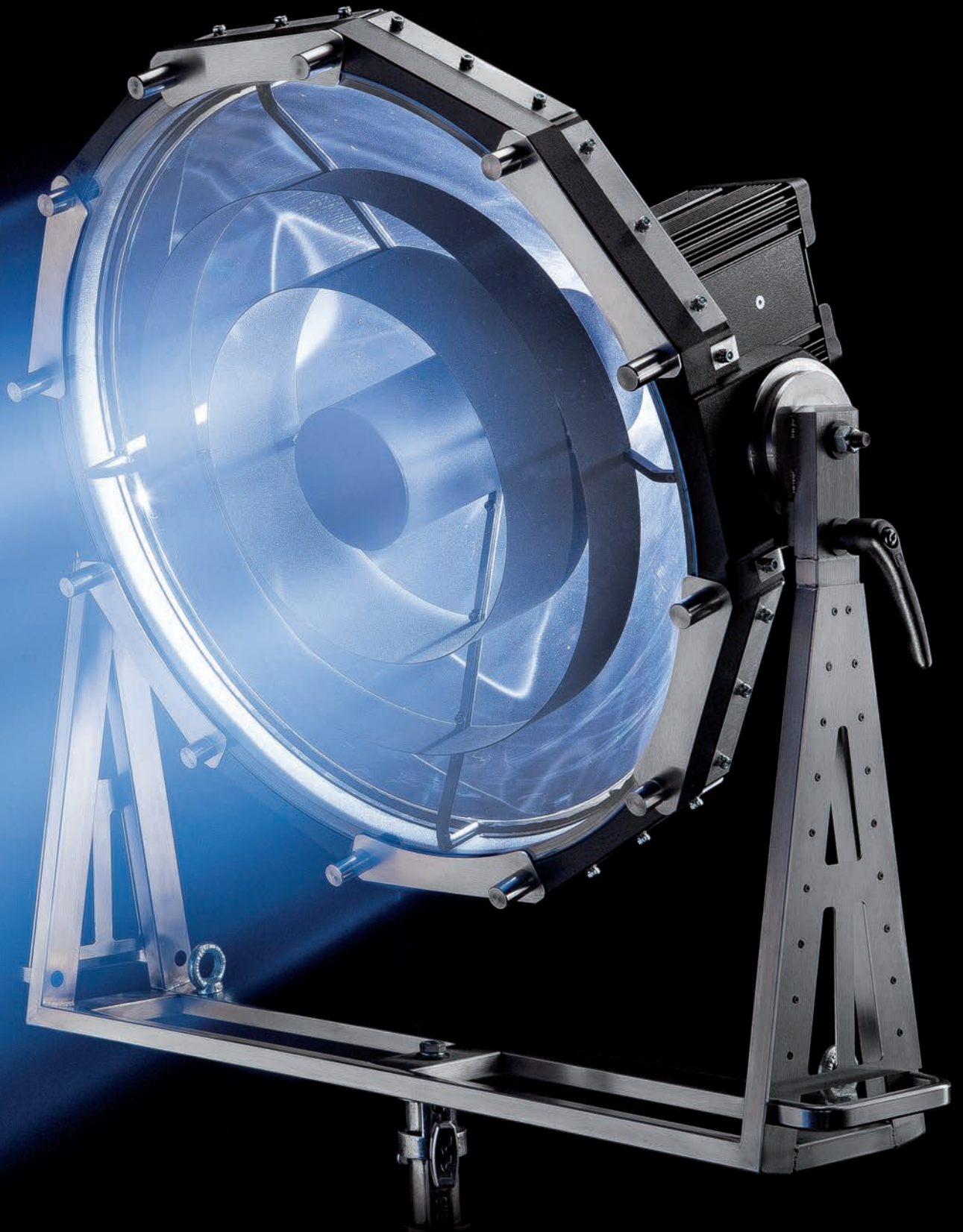

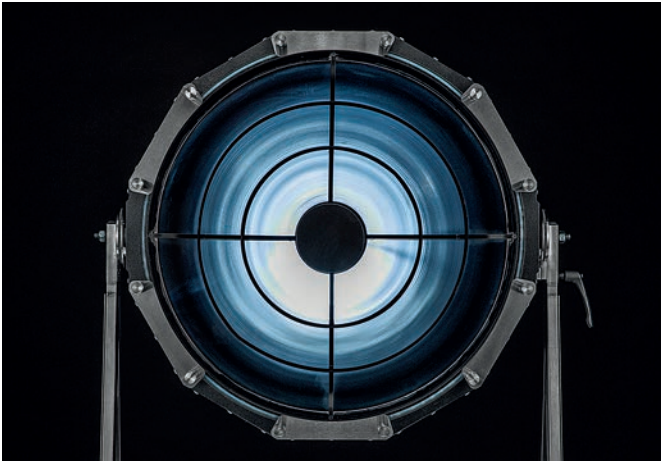

The DBP70 today is our largest and most powerful parallel beam light, mainly directed at the use in Lightstream Drama applications. Beam projectors have been known in our industry, but this one is different, as much as it offers a very defined beam, and at the same time a homogenous light distribution all across the beam.

The beam has an exit diameter of 70cm, 27.5 inches. This parallel beam light fixture can be used for the appearance of a natural light source, being far away by virtue of its character, and its over-ruling of the square law. For this reason, this light fixture has already been chosen for some major film projects to simulate sunlight because of its natural and unique character. dedolight Lightstream and PB70 is also used in several well-known TV series (Magnum P.I. and „the resident...).

When operating this light fixture with reflectors, there is a choice of the largest reflector that we currently provide, using a 100 x 100 cm reflector surface (usually the # 1 type) to redirect the light in an opportune direction, without much change to the beam diameter and the beam character, and without causing much noticeable stray light. Especially, when

such a large reflector, redirecting the entirety of the beam, is used, the result provides a virtual light source at considerable distance. Thus, talent/actors are able to move in the reflected light, without diminishing light intensity when changing position.

This lighting instrument can therefore be used with a large reflector to redirect the light beam in its entirety, or can be used with a multitude of smaller reflectors, to direct parts of the beam in different angles and directions.

Often, a multitude of reflectors is used for secondary and third reflectors, to change the direction of the light, to change the character of the reflected light, and thus, lighting entire scenes from a single light source. The side effect of such lighting practice is to eliminate a lot of lighting paraphernalia from the set without cluttering the set with many fixtures, lighting stands, flags and other instruments.



Sometimes the entire diameter of the parallel beam gets redirected by a large reflector (1x1 meter), no. 1 type.

Other times, several smaller reflectors share the beam to redirect the light simultaneously to several directions and further reflectors.

The deeper you insert the reflector into the beam, the more light becomes active. Thus, you choose a level of intensity without changing color or character. (You could call this: opto-mechanical dimming)

The dedolight Lightstream parallel beam light and reflector system also allows to create many different lighting situations without necessarily altering the color character and color temperature.

By adding further bicolor dedolights, very gentle and subtle use of color temperature change can influence the overall impression of talent, of character in an astounding way.

On the large parabolic DPB70 we can apply filters or partial filters, affecting only one or a selection of reflectors. There is little heat on the large surface of this light.



DPB70 TECHNICAL DATA

Overall outer dimensions: 92 x 100 x 62 cm, **Operational position:** any
Weight: 49.8 kg (109.8 lb), **Use:** indoor/outdoor
Light source: special design, 1200W metal halide lamp with G22 socket specially adapted for function within the DPB70 light fixture
Power consumption: 1200 W

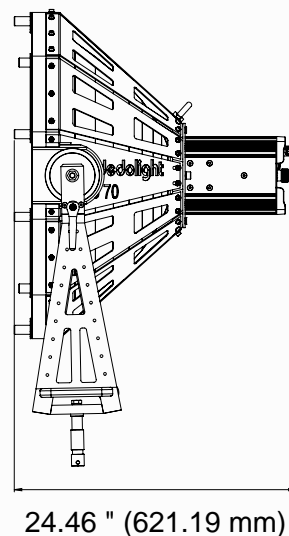
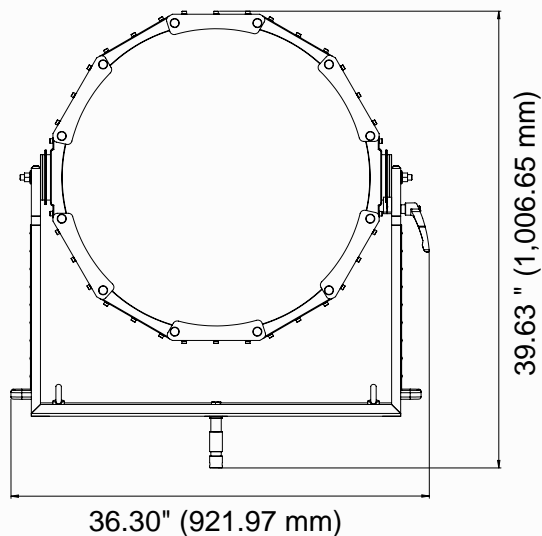

The DPB70 light is powered by the dedolight DEB1200D flicker-free ballast, which also allows dimming of the light source up to 40% and operates quietly and can be controlled by DMX signals.

The DPB70 is rainproof and therefore suitable for lighting setups in exterior and continuous use, even under adverse conditions.

The beam of the DPB70 light head can further be cleaned from remaining parasitic light by adding a honeycomb, which reduces the light output only minimally.

A filter holder can be added for total or partial filtering with gel filters.

A transport case is available (Code: DCHD70) to receive the light head, as well as the ballast or necessary cabling, and three sets of reflectors, as well as a choice of mounting/grip equipment.

SETDPB70

Complete parallel beam light head with ballast, cable and lamp

DPB70

Parallel beam light head (no lamp)

DL1200DHR-PB

1200 W daylight discharge lamp

DPB70HON

Honeycomb

DPB70FH

Filter holder

DCHD70

Transport case

DEB1200D THE ELECTRONIC BALLAST



DEB1200D Electronic Ballast

- Leading edge technology
- Low heat dissipation
- Silent ventilator remains off during normal operation and operates under high heat conditions only
- Active power factor correction (PFC)
- Funktional range from 90-264V AC
- Overload protection
- Surge protection
- Short circuit protection
- Auto start function
- DMX control is included
- Rainproof construction
- The ballast can be opened within 30 seconds – like a book
- Full access to all elements and electronics

DPOW1200D Cable

Connection cable between light head and ballast

Technical Data: DEB1200D Electronic Ballast

The frequency to operate the lamp is switchable from normal flicker-free function to 300 cycles for high-speed recordings

Weight:
11.4 kg

Output Power:
1200W

Input Voltage:
90-264V AC *

Indicators:
3 Status-LEDs (Ready, Lamp, Heat)

Dimming range:
100 – 60%

DMX-Control
DMX control and auto start mode can be chosen.

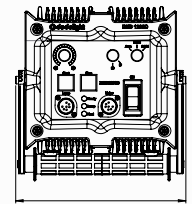

9" (225 mm)

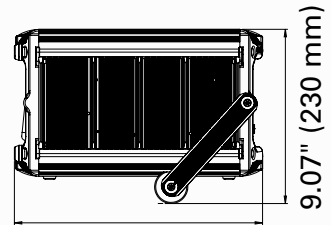

12.95" (328 mm)

9.07" (230 mm)

Stand mounting optional with double-holding clamp: DEB1200H

*) functional range including tolerances

PARALLEL BEAM INTENSIFIERS

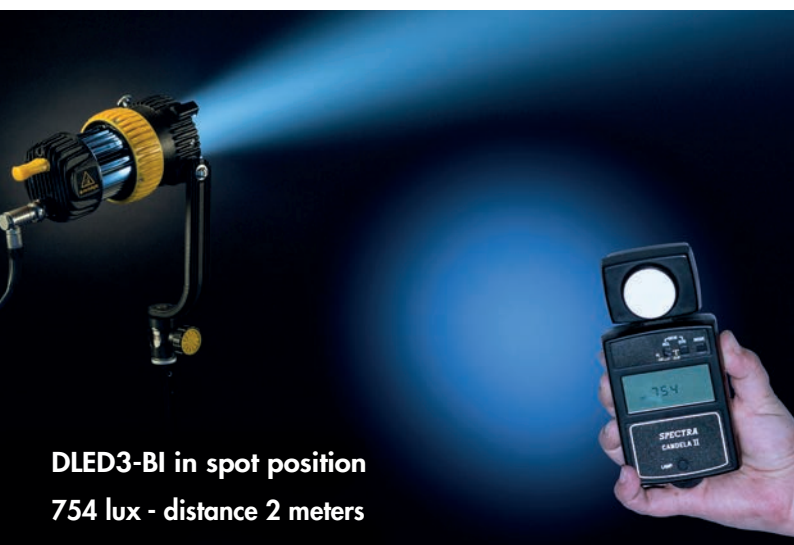

DLED3-BI in spot position
754 lux - distance 2 meters

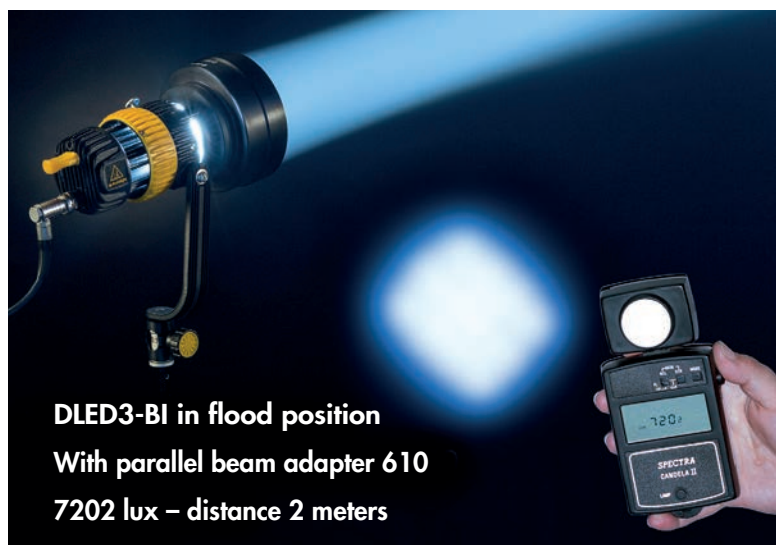

DLED3-BI in flood position
With parallel beam adapter 610
7202 lux – distance 2 meters

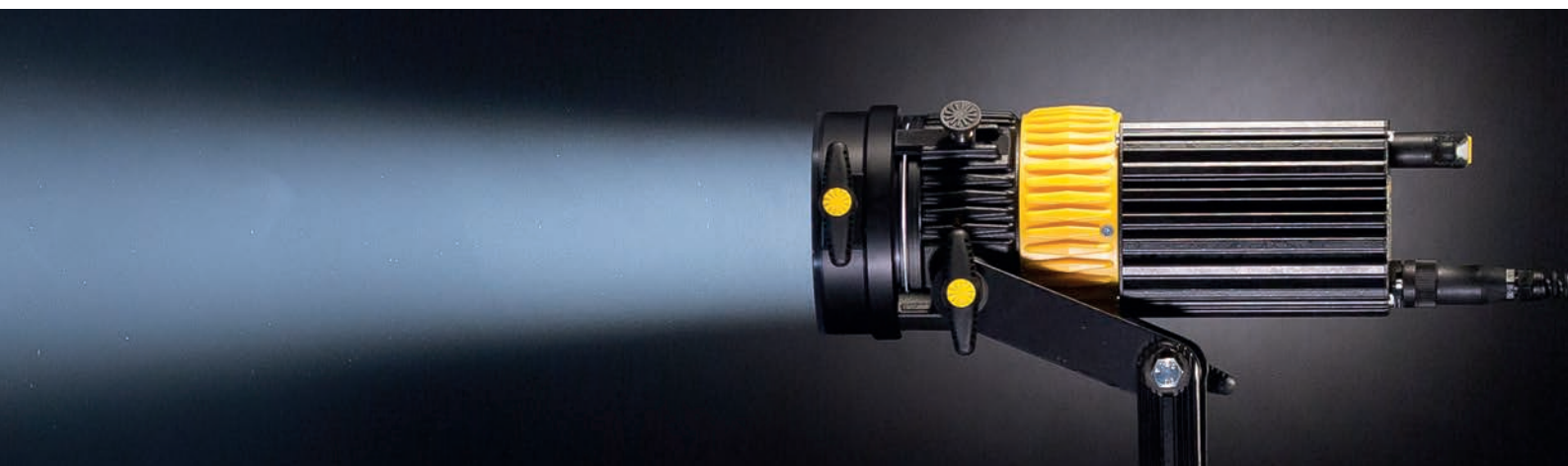

DLH1200 (1200W metal halide light)
Native spot at 4 meter distance: 22500 lux.
Add parallel beam intensifier
DPBA1821: 130.000 lux. Distance: 4 meters



KNOWN DEDOLIGHT FACTS

Focusing dedolights have been conceived with a revolutionary optical system, surpassing any traditional Fresnel concept.

dedolight works precisely calculated non-spherical optics. These were awarded twice by the Oscar Committee of the Academy of Motion Pictures Arts and sciences, and also received an Emmy and other awards for optical achievements.

dedolights offer a wider focus range than any other professional light (bigger variation between flood and spot angle).

The spot performance surpasses any spot function of usual traditional studio lights, be it halogen, HMI or LED lights.

Within the exiting beam, dedolights provide perfectly smooth and even light distribution, not common with traditional lighting instruments. At the same time,

dedolights follows the “clean beam concept”, perfectly smooth within the beam, outside the beam practically no stray light. Thus, the spot performance of dedolights has always been exceptional, allowed to reach far away parts of the set with incredible precision without causing any unwanted shadows.

Furthermore, the dedolight optical concept allows the design of further computer-calculated optics, like the non-spherical wide-angle attachment or the unprecedented imagers for which dedolight also designed specific lenses that are highly efficient and economical and rival lenses used on the most expensive cameras at a fraction of their cost.

Now, the parallel beam intensifiers comprise the latest stage of innovation.

Such parallel beam intensifiers are now available for each and every one of the focusing dedolights.

PARALLEL BEAM INTENSIFIERS

The doorway to reflecting light using the revolutionary dedolight Lightstream system

dedolight Parallel Beam Intensifiers add new functionality to our lights which borderline on the miraculous.

Fundamentally, they allow you the ability to turn any of our focussing lights into multiple light sources. Think about the impact of this ability for a moment; the very real impact of increasing light efficiency and performance while

decreasing budget, time, heat, power consumption, and on-set lighting footprint has staggering potential. Now, even the smallest of fixtures can be used for incredible tasks by redirecting an enhanced beam to Lightstream reflectors. In some cases, the new beam can be multiplied and sent to other locations by focusing on a linear line of reflectors, or to a flat array of reflectors, all of which will become another light source.

For example, our metal halide 400w light (the DLH400DT) can be run at 575w without any detrimental effect on the lifetime of the lamp. It has an extremely high efficiency in spot, with an exit angle of only 4 degrees. Now, add a Parallel Beam Intensifier (additional optical attachment) to this light head and we get some incredible results which continue to surprise us all. The intensifier maintains, but “cleans up” the 4 degree beam in spot while magnifying the intensity of the output by more than double! That is not a typo. When using these amazing Parallel Beam Intensifiers you might think to keep the light in spot, but contrary to that assumption they are designed to be used in the flood position.

It’s important to note that conventional studio Fresnel lights only provide an efficiency of 6% in their spot position, as opposed to the original dedolight dual lens concept which achieves 18%. Based on this, the duplicating of light output over the spot performance is even more significant. But we couldn’t stop at these staggering results; the Parallel Beam Intensifiers described above are roughly the same diameter of the the dedolight front end which they mount to. We now have more magical Parallel Beam Intensifiers with much larger optical systems in relation to the diameter of their host’s front end; these attachments have increased the beam output by up to an incredible 6 times over the native spot performance. It really is miraculous.

The following table explains the increase in beam performance on the DLH400DT.

DLH400DT	Lux @ 2m	Lux @ 4m
Flood position	3.240	861
Medium position (30°)	6.868	1.862
Spot position	27.565	8.774
Parallel beam intensifier (flood)	59.530	17.010

} 2x

Thus, by adding optical intensifiers to relatively small instruments, elite performance can be achieved. This is what supports the hyper-efficiency and beauty of the dedolight Lightstream system.

Utmost Perfection

To make this work in an absolutely optimal way, each parallel beam intensifier is uniquely designed to bond with the unique optics of each focusing dedolight model. Beam diameter and intensity is the bedrock of redirecting and recycling controlled light with the dedolight Lightstream system. dedolight users have come to know why we call our lights precision lighting instruments.

We have invented a multitude of parallel beam intensifiers to generate various beam diameters and intensity, sometimes creating multiple intensifiers for a single light head.

Now, each focusing dedolight model, from the tiny DLED2 to the 150W classics, and up to the 1200W metal halide, all have varying intensifiers, built to optimize the output. But we didn’t stop at our focusing lights, we needed a large-format parabolic beam diameter to feed multiple Lightstream reflectors, so the DPB70, with a diameter of 2.5ft (70cm) and a perfect 2 degree beam spread makes that possible. For some occasions, using a small diameter beam can cover one single reflector, may be perfect for the desired result. If several reflectors need to be covered, perhaps by flat array, or by linear stacking of reflectors in the beam, a large beam diameter could be used, or you can change the focus setting on the original focusing light and widen the beam. The newly directed light, created from the reflectors, can be directed to move in entirely different directions, ultimately creating new light sources. If occasionally you want to use direct lighting with parallel beam intensifier on your light, you might want to smooth out the beam by using our optimizing filters.

Here we show a selection of parallel beam intensifiers and the matching honeycombs, that sometimes can be desirable to avoid any stray light, although with the original parallel beam intensifier the stray light already is minimal.

Please bear in mind that even for dedolight focusing lights which have the same front-end diameter, you may need very different parallel beam intensifiers. Each of these intensifiers is calculated to cooperate with certain, specifically designed optics for the different lights, and also for different light sources. Please consult the look-up table on pages 35-41 for best choice and optimum performance.



DPBA-7

Parallel beam intensifier for classic dedolight low-voltage halogen (DLH4), as well as 200W metal halide (DLH200DT)



DPBA-7HON

Honeycomb for DPBA-7 intensifier

One of the latest additions to the range of parallel beam intensifiers, suitable for DLED10, our flagship LED light for mobile teams, increasing the light output by extra 500%. Usable functional also on our HMI light DLH400D, where it increases the light output by 600% over the already astounding spot performance.





DPBA-18

Parallel beam intensifier for DLH1200D, DLH1000T



DPBA-14HON

Honeycomb fits DPBA-18



DPBA-L18

Parallel beam intensifier
for DLED12-D, DLED12-BI, DLED30-D



DPBA-14HON

Honeycomb fits DPBA-L18



DETAILS, PROPERTIES & PHOTOMETRICS

for our PARALLEL BEAM INTENSIFIERS, suitable for use with dedolight focusing light heads

The following tables provide information on all dedolight focusing light heads, with original flood/spot angle, lux and foot-candle values for spot position of these light heads at 2m and 4m distances.

In the next column you find the same light head performing in flood position, but this time, after the parallel beam intensifier has been included.

The column before last shows the increase in light output (over the mere output in spot position) in percentage figures, after inclusion of the parallel beam intensifier.

The last column gives codes for the different parallel beam intensifiers, performing with those particular light heads.

Please note:

Several of these parallel beam intensifiers by dimension may fit several different types of focusing dedolights, but may not perform as designed.

This table gives you a detailed analysis, which parallel beam intensifier matches which light head for optimum performance.

For example, the DLED7-D will fit two different parallel beam intensifiers, one with small diameter L7, increasing the light output between 160%-190%, whilst the other one with larger diameter, the DPBA-714 gives nearly three times the light output.

In the third table you also find the photometric data with the large DPB70 light in optimum adjustment, for parallel beam use and long throw.

The position of the light source in the DPB70 can be minimally adjusted, and thus, at certain distances the characteristics can be changed to achieve much higher light concentration for smaller areas. What is shown in this table for 2° spot angle, presents the optimum for homogeneity and long throw, an adjustment that should not be changed.

		Flood-Spot angle		spot position of light head 2m distance	flood position 2m + parallel beam intensifier (attachment)	spot position of light head 4m distance	flood position 4m + parallel beam intensifier (attachment)	+% in comparison to spot position	Product code of parallel beam intensifier (attachment)	
DLED2										
DLED2-D	daylight	50° - 5°	lux	3.075	8.750	769	2.188	84% more light	DPBA-L6	smallest package
			fc	286	813	71	203			
DLED2-D	daylight	50° - 5°	lux	2.250	15.300	563	3.825	480% more light	DPBA-610	best
			fc	209	1.421	52	355			
DLED2-BI	daylight	50° - 5°	lux	1.100	3.350	275	838	205% more light	DPBA-BI6	smallest package
			fc	102	311	26	78			
DLED2-BI	daylight	50° - 5°	lux	1.610	8.800	403	2.200	346% more light	DPBA-610	best
			fc	150	818	37	204			
DLED2-BI	tungsten	50° - 5°	lux	915	2.950	229	738	222% more light	DPBA-BI6	smallest package
			fc	85	274	21	69			
DLED2-BI	tungsten	50° - 5°	lux	1.200	6.750	300	1.688	362% more light	DPBA-610	best
			fc	111	627	28	157			

DLED3										
DLED3-D	daylight	50° - 6°	lux	4.800	11.125	1.200	2.781	132% more light	DPBA-BI6	smallest package
			fc	446	1.034	111	258			
DLED3-D	daylight	50° - 6°	lux	4.800	32.000	1.200	7.600	533% more light	DPBA-610	best
			fc	446	2.973	111	706			
DLED3-T	tungsten	50° - 6°	lux	4.650	10.600	1.190	2.450	106% more light	DPBA-BI6	smallest package
			fc	432	985	111	228			
DLED3-T	tungsten	50° - 6°	lux	4.650	28.000	1.190	8.050	502% more light	DPBA-610	best
			fc	432	2.601	111	748			
DLED3-BI	daylight	50° - 8°	lux	1.138	4.550	285	1.138	200% more light	DPBA-BI6	smallest package
			fc	106	423	26	106			
DLED3-BI	daylight	50° - 8°	lux	1.450	8.800	390	2.050	426% more light	DPBA-610	best
			fc	135	818	36	190			
DLED3-BI	tungsten	50° - 8°	lux	838	3.275	210	819	190% more light	DPBA-BI6	smallest package
			fc	78	304	19	76			
DLED3-BI	tungsten	50° - 8°	lux	1.203	7.304	324	1.702	426% more light	DPBA-610	best
			fc	112	679	30	158			

		Flood-Spot angle		spot position of light head 2m distance	flood position 2m + parallel beam intensifier (attachment)	spot position of light head 4m distance	flood position 4m + parallel beam intensifier (attachment)	+% in comparison to spot position	Product code of parallel beam intensifier (attachment)	
DLED4 *										
DLED4-D	daylight	60° - 4°	lux	5.150	12.600	1.288	3.150	145% more light	DPBA-L7	smallest package
			fc	478	1.171	120	293			
DLED4-D	daylight	60° - 4°	lux	6.300	17.800	1.575	4.450	183% more light	DPBA-710	fine
			fc	586	1.654	146	414			
DLED4-D	daylight	60° - 4°	lux	5.150	17.600	1.288	4.400	242% more light	DPBA-714	best
			fc	478	1.635	120	409			
DLED4-T	tungsten	60° - 4°	lux	4.050	7.250	1.013	1.813	79% more light	DPBA-L7	smallest package
			fc	376	674	94	168			
DLED4-T	tungsten	60° - 4°	lux	3.950	13.600	988	3.400	244% more light	DPBA-710	fine
			fc	367	1.264	92	316			
DLED4-T	tungsten	60° - 4°	lux	4.050	15.500	1.013	3.875	283% more light	DPBA-714	best
			fc	376	1.440	94	360			
DLED4-BI	daylight	60° - 4°	lux	4.200	7.602	1.050	1.901	81% more light	DPBA-BI7	smallest package
			fc	390	706	98	177			
DLED4-BI	daylight	60° - 4°	lux	4.350	14.442	1.088	3.612	232% more light	DPBA-710	fine
			fc	404	1.342	101	336			
DLED4-BI	daylight	60° - 4°	lux	4.200	16.170	1.050	4.043	285% more light	DPBA-714	best
			fc	390	1.502	98	376			
DLED4-BI	tungsten	60° - 4°	lux	3.486	6.519	872	1.630	87% more light	DPBA-BI7	smallest package
			fc	324	606	81	151			
DLED4-BI	tungsten	60° - 4°	lux	3.610	11.000	903	2.750	210% more light	DPBA-710	fine
			fc	335	1.022	84	255			
DLED4-BI	tungsten	60° - 4°	lux	3.486	11.434	872	2.859	228% more light	DPBA-714	best
			fc	324	1.062	81	266			

*) For some lights, there are up to 3 choices of parallel beam intensifiers
Different areas of application demand different size/ weight.
Smaller and lighter devices may be more suitable for smaller lighting kit.
Extreme performance can be found with some larger, heavier, but also higher priced options.

	Flood-Spot angle		spot position of light head 2m distance	flood position 2m + parallel beam intensifier (attachment)	spot position of light head 4m distance	flood position 4m + parallel beam intensifier (attachment)	+% in comparison to spot position	Product code of parallel beam intensifier (attachment)	
--	------------------	--	---	--	---	--	-----------------------------------	--	--

DLED7 *

DLED7-D	daylight	60° - 6°	lux	8.500	13.800	2.125	3.450	62% more light	DPBA-L7	smallest package
			fc	790	1.282	197	321			
DLED7-D	daylight	60° - 6°	lux	6.750	20.000	1.688	5.000	196% more light	DPBA-710	fine
			fc	627	1.859	157	465			
DLED7-D	daylight	60° - 6°	lux	7.900	34.500	1.975	8.625	237% more light	DPBA-714	best
			fc	734	3.205	183	801			
DLED7-T	tungsten	60° - 6°	lux	6.100	11.800	1.525	2.950	93% more light	DPBA-L7	smallest package
			fc	567	1.096	142	274			
DLED7-T	tungsten	60° - 6°	lux	6.600	20.500	1.650	5.250	210% more light	DPBA-710	fine
			fc	613	1.905	153	488			
DLED7-T	tungsten	60° - 6°	lux	7.800	33.000	1.950	8.250	223% more light	DPBA-714	best
			fc	725	3066	181	766			
DLED7-BI	daylight	60° - 8°	lux	5.850	10.600	1.463	2.650	81% more light	DPBA-710	fine
			fc	544	985	136	246			
DLED7-BI	daylight	60° - 8°	lux	6.300	18.800	1.575	4.700	198% more light	DPBA-714 (from SN: 1650)	best
			fc	585	1.747	146	437			
DLED7-BI	tungsten	60° - 8°	lux	4.950	9.150	1.238	2.288	85% more light	DPBA-710	fine
			fc	460	850	115	213			
DLED7-BI	tungsten	60° - 8°	lux	5.400	15.000	1.350	3.750	178% more light	DPBA-714 (from SN: 1650)	best
			fc	502	1.394	125	348			

DLED9

DLED9-D	daylight	50° - 4°	lux	14.200	37.500	3.550	9.375	164% more light	DPBA-14	fine
			fc	1.319	3.484	330	871			
DLED9-D	daylight	50° - 4°	lux	15.200	58.000	3.800	14.500	282% more light	DPBA-1419	best
			fc	1.413	5.390	353	1.348			
DLED9-T	tungsten	50° - 4°	lux	8.600	27.000	2.150	6.750	213% more light	DPBA-14	fine
			fc	799	2.508	200	627			
DLED9-T	tungsten	50° - 4°	lux	9.200	35.880	2.300	8.970	290% more light	DPBA-1419	best
			fc	855	3.335	214	834			
DLED9-BI	daylight	50° - 4°	lux	9.250	17.300	2.313	4.325	87% more light	DPBA-14	fine
			fc	859	1.607	215	402			
DLED9-BI	daylight	50° - 4°	lux	8.600	40.400	2.150	10.100	370% more light	DPBA-1419	best
			fc	799	3.755	200	939			
DLED9-BI	tungsten	50° - 4°	lux	7.500	13.500	1.875	3.375	80% more light	DPBA-14	fine
			fc	697	1.254	174	314			
DLED9-BI	tungsten	50° - 4°	lux	7.040	33.000	1.760	8.250	369% more light	DPBA-1419	best
			fc	654	3.067	164	767			

*) For some lights, there are up to 3 choices of parallel beam intensifiers
Different areas of application demand different size/ weight.
Smaller and lighter devices may be more suitable for smaller lighting kit.
Extreme performance can be found with some larger, heavier, but also higher priced options.

		Flood-Spot angle		spot position of light head 2m distance	flood position 2m + parallel beam intensifier (attachment)	spot position of light head 4m distance	flood position 4m + parallel beam intensifier (attachment)	+% in comparison to spot position	Product code of parallel beam intensifier (attachment)	
DLED10										
DLED10-D	daylight	50° - 5°	lux	28.575	50.625	7.144	12.656	77% more light	DPBA-14	fine
			fc	2.656	4.705	664	1.176			
DLED10-D	daylight	50° - 5°	lux	26.000	138.000	6.500	34.500	431% more light	DPBA-1419	best
			fc	2.416	12.825	604	3.206			
DLED10-BI	daylight	50° - 5°	lux	14.400	23.625	3.600	5.906	64% more light	DPBA-14	fine
			fc	1.338	2.196	335	549			
DLED10-BI	daylight	50° - 5°	lux	16.000	64.400	4.000	16.100	303% more light	DPBA-1419	best
			fc	1.487	5.985	372	1.496			
DLED10-BI	tungsten	50° - 5°	lux	11.664	19.136	2.916	4.784	64% more light	DPBA-14	fine
			fc	1.084	1.778	271	445			
DLED10-BI	tungsten	50° - 5°	lux	14.200	56.800	3.550	14.200	300% more light	DPBA-1419	best
			fc	1.320	5.279	330	1.320			

DLED12										
DLED12-D	daylight	65° - 6°	lux	23.063	33.211	5.766	8.303	44% more light	DPBA-L18	fine
			fc	2.143	3.087	536	772			
DLED12-D	daylight	65° - 6°	lux	23.920	102.860	5.980	25.715	330% more light	DPBA-L1821	best
			fc	2.223	9.559	556	2.390			
DLED12-T	tungsten	65° - 6°	lux	18.681	26.901	4.671	6.425	44% more light	DPBA-L18	fine
			fc	1.736	2.500	434	597			
DLED12-T	tungsten	65° - 6°	lux	19.200	80.424	4.800	20.160	320% more light	DPBA-L1821	best
			fc	1.784	7.474	446	1.874			
DLED12-BI	daylight	65° - 8°	lux	22.725	30.991	5.681	7.748	34% more light	DPBA-L18	fine
			fc	2.112	2.880	528	720			
DLED12-BI	daylight	65° - 8°	lux	25.400	102.000	6.350	25.500	302% more light	DPBA-L1821	best
			fc	2.361	9.497	590	2.370			
DLED12-BI	tungsten	65° - 8°	lux	18.407	25.103	4.602	6.276	34% more light	DPBA-L18	fine
			fc	1.711	2.333	428	583			
DLED12-BI	tungsten	65° - 8°	lux	18.000	71.200	4.500	17.800	296% more light	DPBA-L1821	best
			fc	1.673	6.617	418	1.654			

DLED30										
DLED30-D	daylight	65° - 6°	lux	41.625	59.625	10.406	14.906	43% more light	DPBA-L18	fine
			fc	3.869	1.338	967	1.385			
DLED30-D	daylight	65° - 6°	lux	45.200	204.000	11.300	51.000	351% more light	DPBA-L1821	best
			fc	4.200	18.959	1.050	4.740			

		Flood-Spot angle		spot position of light head 2m distance	flood position 2m + parallel beam intensifier (attachment)	spot position of light head 4m distance	flood position 4m + parallel beam intensifier (attachment)	+% in comparison to spot position	Product code of parallel beam intensifier (attachment)	
DLH4 *										
DLH4	tungsten	48° - 4,5°	lux	8.700	14.500	2.175	3.625	67% more light	DPBA-7	smallest package
			fc	808	1.347	202	337			
DLH4	tungsten	48° - 4,5°	lux	7.650	19.200	1.913	4.800	151% more light	DPBA-710	fine
			fc	711	1.784	178	446			
DLH4	tungsten	48° - 4,5°	lux	8.700	36.000	2.175	9.000	313% more light	DPBA-714	best
			fc	808	3.345	202	836			

DLH200DT *										
DLH200DT	daylight	48° - 4,5°	lux	15.100	27.000	3.775	6.750	79% more light	DPBA-7	smallest package
			fc	1.403	2.508	351	627			
DLH200DT	daylight	48° - 4,5°	lux	15.000	39.500	3.750	9.875	163% more light	DPBA-710	fine
			fc	1.394	3.671	349	918			
DLH200DT	daylight	48° - 4,5°	lux	15.100	55.000	3.775	13.750	264% more light	DPBA-714	best
			fc	1.403	5.110	351	1.277			
DLH200DT	tungsten	48° - 4,5°	lux	14.345	24.300	3.586	6.075	69% more light	DPBA-7	smallest package
			fc	1.333	2.258	333	564			
DLH200DT	tungsten	48° - 4,5°	lux	14.250	37.525	3.563	9.381	163% more light	DPBA-710	fine
			fc	1.324	3.487	332	872			
DLH200DT	tungsten	48° - 4,5°	lux	14.345	49.500	3.586	12.375	245% more light	DPBA-714	best
			fc	1.333	4.600	333	1.150			

DLH400DT										
DLH400DT	daylight	50° - 4,5°	lux	28.000	56.250	7.000	14.063	101% more light	DPBA-14	fine
			fc	2.601	5.226	650	1.306			
DLH400DT	daylight	50° - 4,5°	lux	86.000	54.000	21.500	135.000	528% more light	DPBA-1419	best
			fc	7.993	5.019	1.998	12.547			
DLH400DT	tungsten	50° - 4,5°	lux	26.600	50.625	6.650	12.657	90% more light	DPBA-14	fine
			fc	2.472	4.704	618	1.176			
DLH400DT	tungsten	50° - 4,5°	lux	27.200	164.560	6.800	41.140	505% more light	DPBA-1419	best
			fc	2.528	15.294	632	3.823			

DLH652T										
DLH652T	tungsten	56° - 8°	lux	21.304	35.152	5.326	8.788	65% more light	DPBA-14	fine
			fc	1.980	3.267	495	817			
DLH652T	tungsten	56° - 8°	lux	20.000	84.000	5.000	21.000	320% more light	DPBA-1419	best
			fc	1.859	7.807	465	1.952			

*) For some lights, there are up to 3 choices of parallel beam intensifiers
Different areas of application demand different size/ weight.
Smaller and lighter devices may be more suitable for smaller lighting kit.
Extreme performance can be found with some larger, heavier, but also higher priced options.

		Flood-Spot angle		spot position of light head 2m distance	flood position 2m + parallel beam intensifier (attachment)	spot position of light head 4m distance	flood position 4m + parallel beam intensifier (attachment)	+% in comparison to spot position	Product code of parallel beam intensifier (attachment)	
DLH1000T										
DLH1000T	tungsten	56° - 5°	lux	30.000	59.560	7.500	14.890	98% more light	DPBA-18	fine
			fc	2.788	5.535	697	1.392			
DLH1000T	tungsten	56° - 5°	lux	30.600	156.060	7.650	39.015	410% more light	DPBA-1821	best
			fc	2.844	14.504	711	3.626			

DLH1200D										
DLH1200D	daylight	56° - 5°	lux	84.000	178.000	21.000	44.500	112% more light	DPBA-18	fine
			fc	7.807	16.636	1.952	4.136			
DLH1200D	daylight	56° - 5°	lux	90.000	520.000	22.500	130.000	478% more light	DPBA-1821	best
			fc	8.364	48.327	2.091	12.082			

		Spot angle		5m	7m	10m	15m	Product code of parallel beam fixture
DPB70								
DPB70	daylight	2°	lux	106.000	54.082	26.500	11.778	SETDPB70
			fc	9.851	5.026	2.462	1.095	

ATTACHMENT	FITS TO LIGHT HEAD
DPBA-L6	DLED2-D
DPBA-BI6	DLED2-BI / DLED3-D / DLED3-BI
DPBA-610	DLED2 / DLED3
DPBA-7	DLH200DT / DLH4
DPBA-L7	DLED4-D / DLED7-D
DPBA-BI7	DLED4-BI
DPBA-710	DLED4-BI / DLED4-D / DLED4-T / DLED7-BI / DLED7-D / DLH4 / DLH200DT
DPBA-714	DLED4-BI / DLED4-D / DLED4-T / DLED7-BI / DLED7-D / DLH4 / DLH200DT
DPBA-14	DLH400DT / DLH650 / DLED9-D / DLED9-BI / DLED10-D / DLED10-BI
DPBA-1419	DLH400DT / DLH650 / DLED9-D / DLED9-BI / DLED10-D / DLED10-BI
DPBA-18	DLH1200D / DLH1000T
DPBA-1821	DLH1200D / DLH1000T
DPBA-L18	DLED12-D / DLED12-BI / DLED30-D
DPBA-L1821	DLED12-D / DLED12-BI / DLED30-D

HONEYCOMB	FITS TO DPBA ATTACHMENT
DPBA-7HON	fits: DPBA-L6, DPBA-BI6, DPBA-7, DPBA-L7, DPBA-BI7
DPBA-10HON	fits: DPBA-610, DPBA-710
DPBA-14HON	fits: DPBA-14, DPBA-714, DPBA-18, DPBA-L18
DPBA-19HON	fits: DPBA-1419
DPBA-21HON	fits: DPBA-1821, DPBA-L1821

LIGHT HEAD	MAY BE USED WITH
DLED2-D	DPBA-L6 / DPBA-610
DLED2-BI	DPBA-BI6 / DPBA-610
DLED3-D	DPBA-BI6 / DPBA-610
DLED3-BI	DPBA-BI6 / DPBA-610
DLED4-D/-T	DPBA-L7 / DPBA-710 / DPBA-714
DLED4-BI	DPBA-BI7 / DPBA-710 / DPBA-714
DLED7-D/-T	DPBA-L7 / DPBA-710 / DPBA-714
DLED7-BI	DPBA-710 / DPBA-714
DLED9-D/-T	DPBA-14, DPBA-1419
DLED9-BI	DPBA-14, DPBA-1419
DLED10-D	DPBA-14, DPBA-1419
DLED10-BI	DPBA-14, DPBA-1419
DLED12-D/-T	DPBA-L18 / DPBA-L1821
DLED12-BI	DPBA-L18 / DPBA-L1821
DLED30-D	DPBA-L18 / DPBA-L1821
DLH4	DPBA-7 / DPBA-710 / DPBA-714
DLH200DT	DPBA-7 / DPBA-710 / DPBA-714
DLH400DT	DPBA-14, DPBA-1419
DLH652T	DPBA-14, DPBA-1419
DLH1000T	DPBA-18 / DPBA-1821
DLH1200D	DPBA-18 / DPBA-1821

REFLECTORS AND ACCESSORIES

SLR25-4 Lightstream Reflector Kit - 25x25 cm

- 1 blue bag for mounting accessories
- 1 carrying bag for four reflectors
- 2 reflector locks
- 2 articulating arms
- 2 D-clamps



SLR50-4 Lightstream Reflector Kit - 50x50 cm

- 1 blue bag for mounting accessories
- 1 carrying bag for four reflectors
- 2 reflector locks
- 2 articulating arms
- 2 D-clamps



SCLEAN

Cleaning Kit consisting of:

- pair of special black gloves
- microfibre cloth 25x25 cm
- cleaning fluid in 250 ml bottle with spray - attachment
- plastic bag



100 x 100 REFLECTOR – DLR1-100X100

Front surface: Reflector #1

Rear surface: Reflector #4



Motorized/DMX controlled
versions in preparation

MOUNTING DEVICES AND MOUNTING ACCESSORIES



DLGA160

Articulating arm with 16mm stud on each end. 16cm length



DLGA240

Articulating arm with 16mm stud on each end. 24cm length

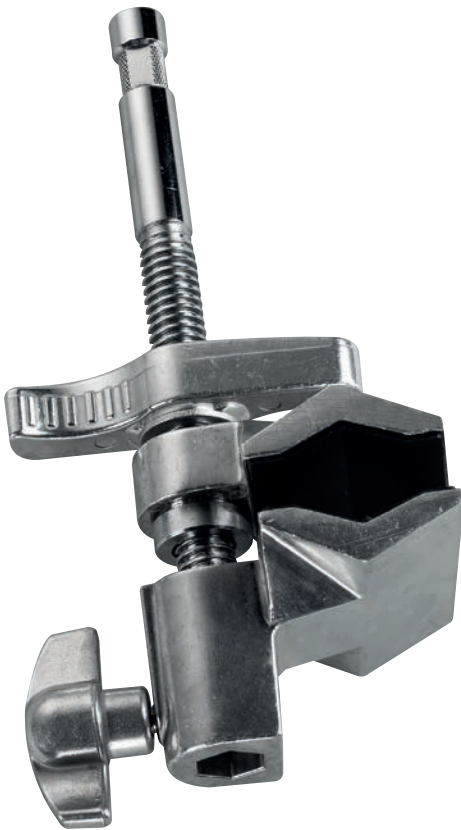

DLR-LOCK

Sliding lock, to attach and lock Lightstream reflectors. Works with DLGA160 arm. Sliding lock, to attach and lock Lightstream reflectors. Works with DLGA160 arm and all other grip devices, ending in a 'baby' stud (16mm).



WG-FW-CC27

A sturdy, heavy-duty clamp with 16mm (baby) stud AND 16mm (baby) receptacle.

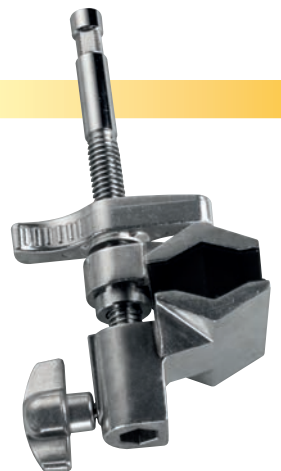

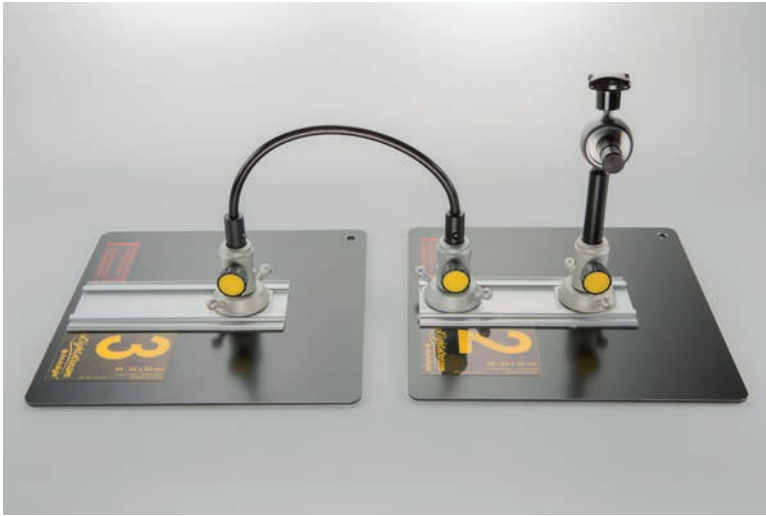

DLRFX40

Lightstream Flexible Extensions 40cm

The main reflector is attached to a lighting stand with a reflector lock and a Lightstream articulating arm in the usual way.

A second reflector lock can be slid onto the main reflector to hold a short flexible extension. This enables two reflectors to be used side by side on just one light stand, saving setup time and space.



DMFC40

dedolight mounting, flexible coupler

with 16mm stud on both ends. Length 40cm (15.8 inch)



DMFC29

dedolight mounting, flexible coupler

with 16mm stud on both ends. Length 29cm (11.4 inch)

MOUNTING DEVICES AND MOUNTING ACCESSORIES

Interesting about the Lightstream system is that one beam can feed a number of reflectors, all linear in a row. In such an arrangement not each reflector gets the full light exclusively. There will be shadows from one reflector on the other, but this system still works very well.

Since the depth into which the reflector surface is dipped into the active beam defines the amount of reflected light (opto-mechanical dimming), a far-away reflector, serving with a larger lit area can reflect the same amount of light as a reflector close by the light fixture, where only a smaller area of the active beam is used.

Another interesting practice is to put a harder reflector right in front of another bigger softer reflector. Thus, lighting the same direction, the same object, the smaller reflector may put an accent and a highlight onto the object, which is being lit by the larger softer reflector. Usually, one would have two separate lighting instruments to do this, causing two separate shadows. This way we can have the light coming from exactly the same direction – no double shadows.



Of course the smaller reflector can also light other subjects which are not even considered by the large reflector.

70x120



here shown with a special non standard reflector allowing the angling of any of our bigger reflectors when using two separate of these adjustable holding arms

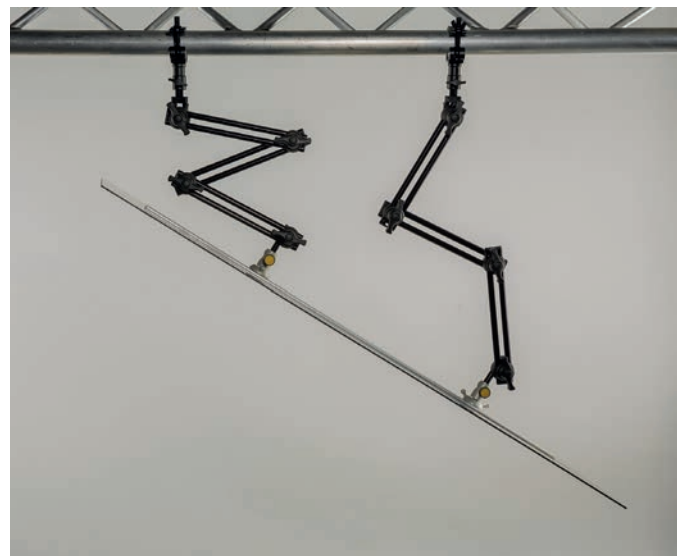

MOTORIZED CONTROL



DLR-MCB

Control box for motorized sliding locks.
2 outputs. Comes with DLBCA2-V belt clip,
DDCC-DTAPS cable and DLPS-12.



DLR-MLOCK

Motor control attachment for
reflectors: 50x50 cm, 25x25 cm,
7x10 cm - controller for 2 motors

Motor: 2 axis

WG-FW-AA6

Double articulated
arm 3 section



WG-FW-CC11

Grip Clamp, Baby
Receiver for pipes
up to Ø 52 mm



DCAB4MINI-10

cable long - 10m



DCAB4MINI-3

cable short - 3m

DMX CONTROL



DLR-M6CB-DMX (Raffael mit Marco noch klären)

With the DLR-M6CB-DMX DMX-motor-controller up to 6 motors can be operated. You then can adjust pan and tilt of your reflectors through manual or computer DMX desks. You can place and preposition the reflectors in places you can hardly reach once the set is built up. It will speed up the work on a complex film set or enable interactive Lightstream setups in automated broadcast studios.

Technical Data:

Input voltage: 12V DC

Power: 8W

Power supply: DLPS12 (100-240V)

DMX IN/Out: XLR 5-pin DMX512/1990 with auto termination

6x Motor-Out: mini XLR 4-pin connector

Mount: can be mounted via DTHC power supply holder and Clamp-C on rods.

DLPS-12

AC power supply (100 - 240 V) with 12 V DC, 18 W output, incl. EU/USA/UK/AUS input connector set. For Ledzilla LED light heads

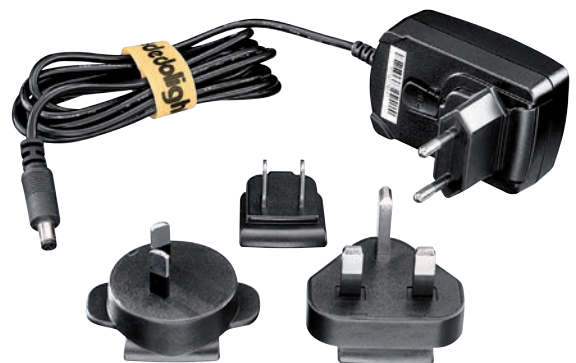

DMX CONTROL AND WIRELESS SOLUTIONS BY EXALUX™

DMX control via cable

Most of the dedolight fixtures can be controlled via DMX protocol.

Dedo Weigert Film Company supplies a variety of lighting desks for different applications; commonly DMX fixtures are connected via DMX cables.

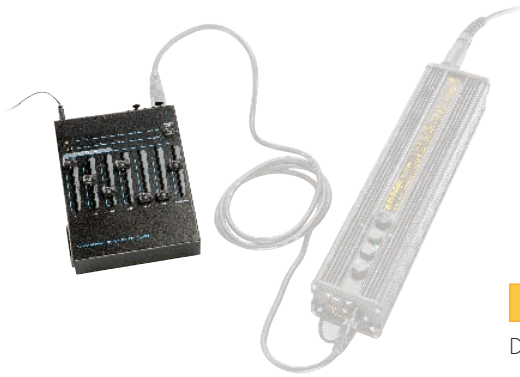

DLSDC-12

DMX-mixer 12 channel

Wifi to DMX control via cable

With the Connect One System from EXALUX™ the gaffer has a solution to control DMX fixtures via WiFi through Android or iOS smart devices.

On sets long DMX cable runs can be avoided between lighting desk and fixtures and hence enable fast operating.

The Connect One Systems operates as a WiFi access point and translates WLAN into one DMX universe with 512 addresses.

EXALUX™ offers intuitive DMX Apps Connect and Connect+ for easy operation; yet the system can work also with sophisticated APPs from other manufacturer.



EXA-C1K

Exalux Connect One Kit

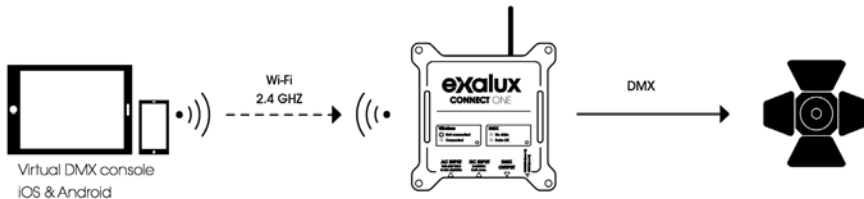

DMX control via wireless

For Wireless Operation the EXALUX™ Connect X100 Wireless Solutions replace your DMX cable by a wireless link.

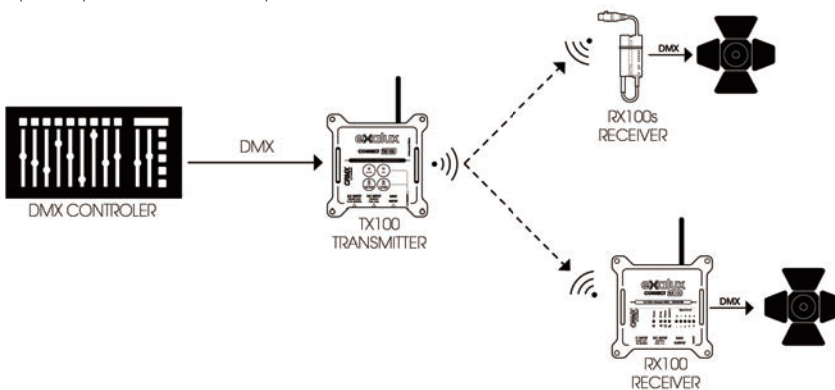

EXA-CNT5

Connect RX100s „BASIC“

EXA-CNT1.1

Connect TX100+RX100 Set

SOFT BAGS FOR DEDOLIGHT LIGHTSTREAM REFLECTORS



DLRP50

Pouch for six dedolight Lightstream reflectors 50x50cm

1.

DLRP25

Pouch for six dedolight Lightstream reflectors 25x25cm

2.

DLRP10

pouch for four dedolight Lightstream reflectors 7x10cm.

3.



DLRP100

Soft bag for large dedolight Lightstream reflector 100x100cm, with frame and yoke.

HARD CASE FOR DPB70

The Hard Case for the DPB70

width: 80 cm x height: 104 cm x depth: 90 cm

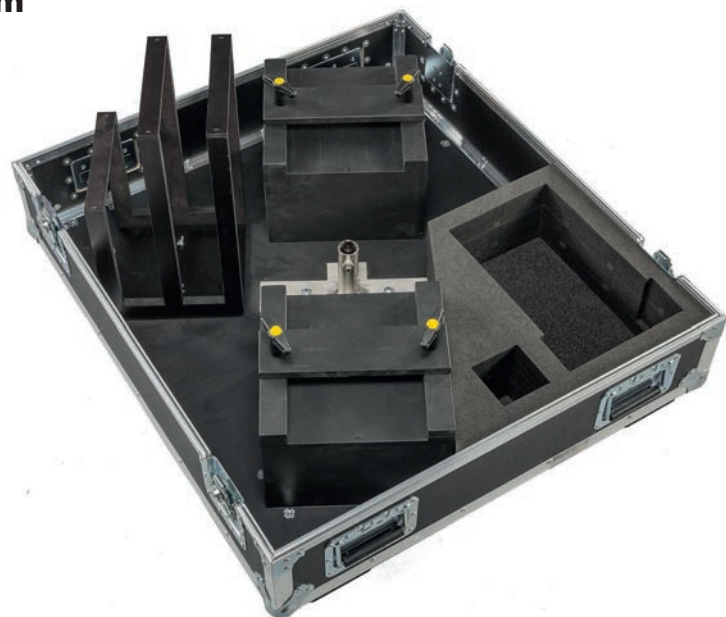

for DPB70 light head, 3 soft bags for reflector sets, Ballast DEB 1200D, head to ballast cable, spare lamp

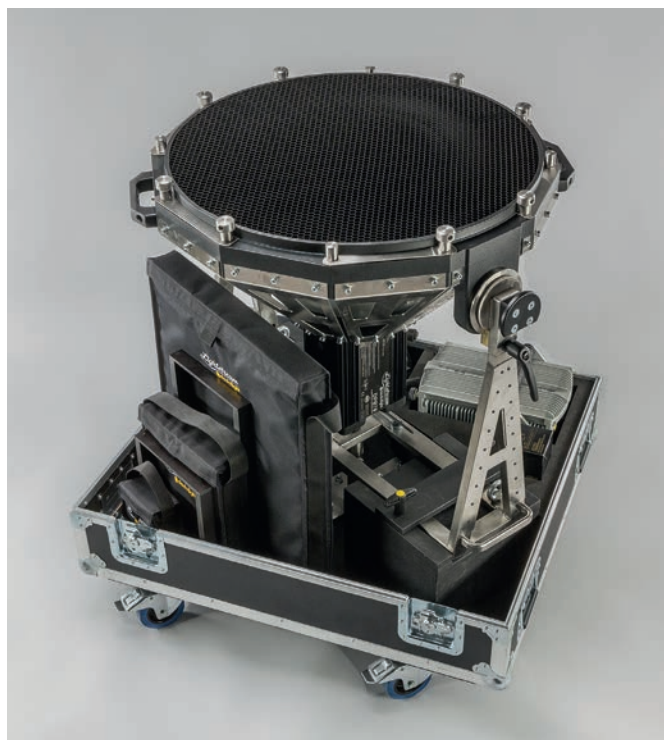

CASE FOR REFLECTOR SET



Case for complete set of Lightstream reflectors, grip and control accessories, but without content.



Case filled with complete set of Lightstream reflectors, grip and control accessories. For content and variations thereof (your choice), see price list. Case filled as shown in picture below.





British DOP

His views on Lightstream

Ian Murray is a professional cinematographer; he has worked in the TV and film industry for over 22 years and has carved a distinguished career in commercial advertising production over the last 20 years.

Ian suffered with dyslexia and truly found his forte when he enrolled with the London College of Printing and studied and passed the BA in Film and Video with the only Distinction in his year.

He is best known for the 250+ commercials short films and music videos that he has shot over his commercial career. During this time he has become an industry expert on film and photography lighting and has taught these subjects in different seminars and workshops for both students and professionals.

Of the hundreds of commercials, short films and music videos he has shot many have earned special recognition and he has become a sought after Director of Photography for a broad scale of productions. From large-scale, multi-camera, multi-unit global campaigns to the precision of table-top model animation, Ian is sought after and constantly in demand. He manages not only to develop his general work but has also gained access to the exclusive areas of hair and beauty, food and drink and sports photography and filming. He is an industry approved hair and beauty specialist and an approved food and drink specialist.

More recently He has begun mentoring and training individuals within the industry. He has taught film lighting techniques and has given lighting seminars and workshops for both students and professionals.

dedolight LIGHTSTREAM, a reflected light system.

Creating a virtual environment of reflected light to reproduce nature in all its complexity and beauty.

Reflected light:

In day to day life we visually experience the world through waves and particles of light. Originally emitted from a source, the sun, for instance and then cascading out in a multitude of reflections illuminating as they go. We see light reflected everywhere, from every object we perceive, to every environment we experience. In essence light is reflecting back at us; constantly shaping our experience and consciousness.

Therefore, when you see such as a beautify lit day time room, you are seeing the playing out of a combination of reflected light, sometimes with the addition of the direct or diffused sun rays, sometimes just reflected light in all its varieties

A chorus of light -First analyse the light:

You can evolve your awareness to light by understanding the subtleties of the multitudes of this reflected light. I find it a useful tool to dissect the different characteristics of light in the following ways:

First notice the direction of the light and its primary "character" in terms or hardness/ softness. Unless you are in a black studio with a single light source you will always be dealing with a primary illuminating source and a multitude of reflected light waves, all with their individual character, these make up the overall "chorus" of the light. You will need to be able to "detect, dissect and consider" all the individual influences of the light, it's like being a detective. For instance, on the human face look at the nose shadow and the eyes for clues.

Once you have determined the direction and primary character, go deeper and become aware of the following.

- What are the colours present in the light, how do these colours shift and relate to each other?
- Become sensitive of the “personality of reflection” in other words how the image of the source, in this case, the reflector used, is cast onto the object/subject. For instance, a silver reflector created a silver cast on the skin of the subject.
- How parallel are the shadows, if sunlight then they will be parallel, if a closer source then they will start becoming divergent?
- What are the additional textures and movements, if any, of the light? For example, tree branches or curtains creating a breaking up and colouring of the light rays.

All of these characteristics contribute to the story that the lights conveyed or As I like to think of it the “narrative of the light.”

For instance, by studying the way a certain landscape at a certain time of day would affect the light reflecting into the window of a room we deepen our understanding of how light plays out. In turn these fuels our ability to produce images that have a richer atmosphere, subtly communicating the time of day, location, and intended mood thus adding to the storytelling of a given scene.

A Virtual landscape of light

We often need to recreate the light that would exist in nature, at a certain location during a certain time of day. We can imagine, in effect a “virtual landscape of light”. we can ask ourselves where is the sky the brightest how does it graduate from light to dark with what colour shifts. What buildings and trees are around how are they reflecting light, what are the buildings made up of, for instance a red brick housing estate with large windows reflecting the sun or a single aged concrete tower block hanging in the cityscape of a cloudy sky... will produce their own signature of colours textures and characteristics.

How to Re-create a chorus of light: The Cinema and photographic reflected light system: LIGHTSTREAM

Now we have discussed the richness and depth of reflected light that existed all around us. Our job as filmmakers and photographers is to try and recreate its subtle beauty and texture in order tell stories and create striking photography.

In the following text I will explore the LIGHTSTREAM and how it compares to the more traditional ways of lighting. Of course, all cinematographers are using reflected light every time they place a light, sometimes more explicitly when “bouncing” light, sometimes just by the physics of the light reflecting around the environment. I have been a fan of the quality of reflected light for most of my career, experimenting with different reflective surfaces, silvers, pearls and white. I have not however been able to improve it more than the standard film practises of bouncing light onto crude surfaces using traditional lights.

LIGHTSTREAM, however is a full system of reflected light application and it's going to change the way you view film/ photographic lighting, deepen your awareness of light and aid greatly in the way you approach the task of film lighting.

The Tools

With LIGHTSTREAM the light is channelled from controlled parallel beams onto a sequence of specifically designed reflective surfaces. This system fully integrates and enables a mastery and efficiency of lighting never before imagined

dedolight have custom built and adapted a whole range of lights and reflectors that are Specifically designed for this system. They can be used to light everything from the largest film set to the smallest product shot. This greatly facilitates your ability to beautiful light a subject with precision and speed.

Before moving onto the actual tools of LIGHTSTREAM its important to understand a couple of key concepts of light that relate to the Dedo parallel beam light, namely: "the inverse square law"*** and "virtual light distance"***.

It must also be understood that a parallel light source produces a Virtual light distance far greater that the actual distance the light is from the subject. As mentioned, when you evaluate shadows, you look at how parallel they are to determine the distance of a light. Therefore, if you analyse the exit angel of the parallel source and plot it back until it converges that is its virtual light distance. This is a key component to producing convincing sun rays and a naturalistic light. ****

So, now let's have a look at the tools: The central lights of the system are the PB70 (parallel beam 70cm) and the PB30 (parallel beam 30cm, its little brother)

PB70

PB70 allows for the purest approach to the LIGHTSTREAM system. It produces a very powerful, broad, parallel beam of light, powerful enough to mimic the sun and broad enough to allow multiple reflectors into its path. It is manufactured to the highest standards producing a highly efficient output of light. * . With consistent light across the beam, free from stray light and only producing moderate heat even when switched on for several hours. There is no other light fixture currently made that can outperform the PB70. As a traditional film light, it's simply state of the art. However, it has been designed as the centrepiece the LIGHTSTREAM system and as you will see, its features support a whole new way of lighting.

Only 1.2kw of power but a far higher light output due to its reduction of destructive interference

PB30

The PB30 is a smaller version of the PB70. It has a 30cm reflector as oppose to the 70cm reflector of the PB70. It maintains the same power output with its 1.2k bulb; therefore, It's fantastically powerful for its size. The only drawback is due to the smaller beam size you cannot fit as many reflectors in its path as the PB70.

dedolight 400 and 200 range:

For supplementing the PB70 and PB30 or for minor set ups the smaller lights in the range can be used. By modifying these lights with a “parallel beam adapters”, the light beam is channelled into a reflector more efficiently with more precision and intensity. These adapters almost defy physics by producing up to 3 times more intensity of the light you would get if you simply “spotted” the light into the reflector. This is due to its lens design and a reduction of destructive interference.

The Parallel beam adapters are currently made the following dedolight lights:

- 400 series
- 200 series
- Classic series
- LED series

This produces a comprehensive range of smaller lighting fixtures, that will fit into the most cramped location or compromised situations.

Which method you choose for the most part will be determined by the application.

For example, when dealing with lighting through set or location window you will probably want to start with the PB70/30 outside the window. In most cases you will be able to light the whole room from just this one light. Sometimes the need to supplement the light may arise, this can be done by channelling the light onto another reflector from the PB70/30 or using a smaller fixture in the room and channelling that onto its own reflector.

Therefore, they are 3 approached to using LIGHTSTREAM:

1. Using the PB70/30 with a multitude of reflectors.
2. Using smaller individual lights 400, 200 or led series with their parallel beam and respective reflectors.
3. A combination of the two.

Now let's move onto the reflectors

Reflectors are the light producing, redirecting and sculpting elements of the system. They can precisely define the quality of light and adjust the distribution and intensity of light.

The reflectors are precisely measured reflection mediums constructed from aluminium panels with reflection enhancing hi-tech coatings. Ensure reflection values between 78% and 96%

They have been designed to define the light distribution and the light modulation precisely.

The characteristics of the reflectors are consistent. Independent to the surface area illuminated.

Currently the reflectors come in 4 grades from soft to hard and 3 sizes; 1-meter square, 50cm square, 25cm square and 10cm x 7cm. They are mounted onto a slide and lock bracket that allows precise positioning into the beam of light. Once the position is found they lock with a twist clamp.

The four grades range from soft reflectors producing diffused yet structured light to hard reflectors redirecting the light precisely, without changing its shape or defusing it with only 3% loss of intensity.

To fully understand the versatility of these reflectors you need to also define them in terms of the exit angle of the light. Hard reflectors having a narrow exit concentrating the light within the beam and soft reflector a wider exit, scattering the light and widening its influence. The soft reflectors have an extraordinarily high reflectivity; however, since the light is spread over a larger area the intensity will be reduced.

The **reflector No1** is the light redirecting reflector it has a narrow light exit, maintaining the parallel beam. Light can be channelled around the set with minimum fall off or scattering.

The No1 reflector produces a convincing sun light with clean hard parallel shadows and no colour fringing.

It should be noted that the 1 reflector is not a mirror. A mirror changes the reflection of the source, influenced by reflecting directly the surface flaws of the mirror. Whereas the No1 reflector maintains the homogeneity and character of the source just redirecting it not changing it.

No2 reflector has a wider exit angle, 12 degree; however, the reflected intensity remains at 95-98%, it's a very useful reflector for redirecting the light onto another reflector with a larger surface area.

No3 reflector has an exit angle of 50 degree. This reflector is gentler with the same amount of light reflected but dispersed over a larger area.

No4 reflector is the gentlest reflection with an angle of 95 degree. Close to styrofoam in softness but more structured.

It's worth noting that the virtual distance is fully in effect with reflector No1 as the reflectors soften the effect quickly diminished as the light is not being redirected but scattered with the reflecting surface becoming the light source. By the time you get to No4 reflector there is not really any noticeable difference between the virtual light source and the front surface of the reflector.

The intensity of light is determined by merging the light into the light beam. If you put the reflector all the way into the light beam, and the entire reflector works, whilst, if you insert only part of the reflector into the light beam, less light will be reflected.

Regardless of how much light hits the reflector the colour, direction and spread derived from the surface remains the same. The shadow appearance (with regard to the hard/softness) proportionally change depending on the size of the source or in this case how much of the reflector is illuminated

When the LIGHTSTREAM reflectors are used in sequence, another dimension of possibilities opens up. By selecting a source reflector by its exit angle, you can manipulate the amount of the target reflector that is illuminated. By adjusting the portion of the target reflector illuminated you are determining how hard or soft the light produced is.

Therefore, your choice of reflector and the amount of light you allow onto it to determine the quality of the light. Allowing precise control and fine adjustment.

Light distribution, modulation, can be adjusted precisely

Merging into light beam and locking off precisely. You had never had so much control, speed and precision in placing light. Allowing quick switching between soft and hard light reflectors. You have a full range of lighting textures at your fingertips. You simply select a reflector and determine how far to merge it into the beam, and where to channel its light into the set.

Moving away for the artifice of film lights:

When we view an object, we see light reflected back at us. Therefore, you could say that light does not come from the light fixture light comes from the object, the light fixture the audience should not be aware of.

Therefore, as filmmakers we want the audience of our work to feel the emotions of the light without being aware of the equipment we use to shape it.

Film lighting fixtures usually require further manipulation in order to recreate natural looking light.

As a result, we usually have to substantially modify the light. It's this modification or "Shaping of the light" that is the essence of film lighting. However, traditionally it requires the use of a wide variety of additional equipment. Its time consuming, expensive and restricting to both the director and actors.

The BP70/30 produce an exceptionally clean parallel beam of light, This has many advantages over traditional film light:

To start to understand the benefits of this system lets look at one of the most difficult tasks of a film light; to imitate the qualities of sunlight.

By virtue of the sun being a faraway incandescent ball of hot gases, it produces a certain quality of light. By the time it reaches the earth it's relatively small in size and thus becomes a specular point source of light. It produces hard clean, parallel shadows and is consistent in light intensity due to the inverse square law, with no reduction or "fall off" of light intensity over the distance on earth it illuminates.

To create natural looking sun light, a film light needs to imitate these qualities, DOPs will traditionally use a very large powerful light **** far away from the film set. The further away the light is placed from the subject, the harder, cleaner, more parallel the shadows and the less "fall of" of light intensity.

This comes at a cost, A powerful light set back requires a large noisy generator, cherry pickers or heavy stands and additional crew. All of this takes time and money; however, the biggest drawback from a lighting perspective is It will not allow for lighting precision. It is very hard and time consuming to get this light positioned and shaped.

The LIGHTSTREAM is a completely unique approach to creating natural looking light, and overcomes these problems in a beautiful and elegant way.

The PB70/30 generates a clean parallel beam of light at its source, producing crisp clean parallel shadows. This light beam defies the inverse square law, its fall off in intensity is far less than a traditional film light. This along with its virtual distance means it can be used a lot closer than a traditional film light. It does not have to be so big and powerful to produce convincing sunlight with minimal light fall off.

This beam is projected into a series of reflectors, modifying the beam further and creating even cleaner more natural looking light rays.

Furthermore, this effect of natural sunlight is further enhanced by virtue of reflecting the light. This adds an additional increase in the virtual light distance. * * * *

The PB70/30 are very quick and easy to set up, both lights can be used facing directly up from their flight case, you just wheel it in take the lid off and power it up from a domestic wall socket.

The light is easy far easier to move and shape. Than the traditional method. After all a reflector in someone's hand is far easier to move than a larger heavy light far away.

In Essence the PB70/30 produce the most efficient, precise, natural looking light I have seen from a "film light". Producing a purity of light that the best lighting tools currently available struggle to imitate.

Less equipment, more lighting precision.

To get the most effect from the LIGHTSTREAM system and for the majority of set or location lighting applications you would usually want to start with either the PB70 or PB30 light. And then supplement it with the smaller lights if needed.

Often times placing them outside the window firing it directly up into the reflectors. Using multiple reflectors to channel all the different qualities of light through the window into the room.

The control of the beam and the shaping of the light is happening at the source, with the selection of the reflector and its position in the beam of light. This is a really important point. And makes a huge philosophical and practical difference to the approach of lighting a film set. Therefore, all the equipment traditionally associated with modifying the light, stands flags, nets, floppies, sand bags etc... are not needed, in fact very little equipment is needed in the room at all, just maybe additional reflectors to redirect the light. Thus, creating great freedom for the director and actors.

Zoning the light

The LIGHTSTREAM is a simpler way of lighting producing a more complex texture result. Resulting in motivated light with more complexity and shape but delivered in an effortless simple and natural way.

The light can be built up in stages with unprecedented precision. By virtue of the control and ease with which the light is directed without spill and mess you can zone the light creating more depth and texture, from hard naturalistic sun rays to soft yet structured light. You are able to produce the most intimate touches of light, from broad strokes to fine detail. You can build up the light in layers or "zones" defining individual areas of the set.

Since you are only dealing with a single beam of light, the multiple reflectors do not produce double shadows, as would happen with multiple lights and a rich tapestry of light textures is created, individually structured and zoned into the film set.

The LIGHTSTREAM when used with the PB70/30 is particularly suited for recreating convincing sun and consecutively a multitude of additional lighting textures with just the one source of light. The characteristic that is so striking when you first see the LIGHTSTREAM at work is how un-lit yet 3 dimensional the set looks. Its effortlessly naturalistic with shape and structure to convey the 3-dimensional reality onto a 2-dimensional screen, you can really feel the presence of the light without feeling the presence of "film lights".

Dynamic light

When assessing a hi-fi speaker's ability to reproduce sound, the term "dynamic" is used to assess the ability of the speaker to switch from loud to quiet with a minimum of distortion. We could borrow this term and apply it to the ability of a lighting fixture to blend from hard light to soft with a minimum of distortion. For instance, unwanted or double shadows, colour fringing, in fact any mechanical artifice that give away it's film lights being used to illuminate.

Controlling the degree of hardness and softness in lighting a scene, and how they interplay is fundamental to the success in creating depth shape and atmosphere. What is unique about the dedolight LIGHTSTREAM system is its ability to produce this type of dynamic light effortlessly and in the most natural way.

The sophistication of combining the light and building it in layers, allows a multitude of different lighting textures. Rather than a soft light as sky and a hard light as sun. The hard shaft can literally be placed within the soft shaft. A single source with a rich textures variation of soft and hard.

From the polarised light of a hard reflector with a mirror to the broad beam of the PB70 producing an even spread of light over the surface of a soft white reflector. This subtlety and control of the dynamics of the light is unique to this system of lighting.

Time spent lighting not rigging.

The great satisfaction with this system is that the vast majority of the time is spent actually lighting. Moving and shaping light around the set. Not running cables placing stands and flags. Traditionally a Director of Photography will spend 80% of his time waiting for light to be powered and placed only then can a decision be made on the aesthetics usually with traditional methods, it's the last 10 minutes that the finessing and actual shaping of the light happens, and it's the most pressured 10 minutes often with the director and producer wanting to start shooting. With this method, you're finessing the light as soon as you place your first reflector, often only having to place a single light

Light Channels: rather than cables.

By projecting the light across the room and catching it in a secondary reflector. You are in essence creating channels of light, dispensing with the need to place additional light fixtures and run cables. You simply can channel the light to where you want it. Spend your time finessing the light not running cables and placing stands.

Colour: Quicker Colour control

These benefits of control speed and precision can also be applied to the colouring of the light. Because of the cool running of the light the gels can be placed directly on the front glass. In most cases you will be firing the light straight up; therefore, the gels can quickly be placed on the glass and moved around with ease.

Control colour with simple gel placement:

Simply by placing small pieces of effects gels onto the glass of the PB70/30 to get the right graduation and offsetting the reflectors we can go from an iridescence tropical summer morning light to a northern autumn twilight. It's never been quicker to make colour changes, with dramatic shifts of time of day and overall mood.

This is revolutionary, being able to colour the lights quickly is a huge benefit. In traditional methods, with a light of this power you would need to have a separate frame and stand to place the gel away from the heat of the light, even then the gels burn through and discolour. The frame takes time to make up and used a lot of gel. The DOP needs to be sure he/she will use it to commit to such expense and work. However, with LIGHTSTREAM you simply take small pieces of gel and move that around the surface of the light until you have the colour composition you want. This method works best with either Polyester or even better Polycarbonate (for instance the Rosco Super Gel) The Acetate gels being the least resistant to heat. Dedo is in the process of conducting tests to clarify the amount of time they will withstand the heat.

Because of the method of placing the gels on the area of light that covers a certain reflector. There is nothing stopping you from offsetting the gels to only cover a proportion of a certain reflector or covering several reflectors at the same time. It's just down to the size of piece the gel cut and where on the glass its places.

You can therefore select and "zone" the individual reflector into different colour temperatures and effect colours. This speed and ease of colouring light generates a playfulness that allows the DOP to try things out and take more risks with perhaps bolder colours or unique colour combinations. I believe part of the new wave of cinematography is a more sophisticated use of colour and this system supports that development also.

In summary:

For a creative individual, you can now understand that the control and freedom that is afforded by LIGHTSTREAM is unprecedented. dedolight have devised a system that brings a purity and immediacy to lighting, stripping away fixtures and placing the light literally in the palm of your hand, removing obstacles and offering a higher level of intimacy to produce a more naturalistic light.

An intimate relationship with light is essential in crafting nuanced stories. It is my belief that a small commitment to learning this system will empower the filmmaker and photographer, unlocking a set of tools with limitless possibilities.

Foot notes:

**The inverse square law (a physical law that states light falls off in intensity disproportionately to the distance of the light to the subject.)

*** Virtual light Distance is the distance a traditional light would need to be from the subject to match the fall off and shadow characteristics of a Dedo parallel beam light. This is calculated by tracing the angle lines of the beam back to a point where they converge.

It should also be noted that the virtual light source is further increased when the light is redirected with the hard reflectors. This can be measured by the sum of the light passing from the fixture to the reflector then onto the subject.

In other words, if the reflector is 10 feet from the source and the subject another 10 feet from the reflector then the "relative light travels is 20 feet thus reducing the effects of the inverse square law.

However, this effect depends on the surface of the reflector. The harder the reflector the more the virtual distance is in effect. With the soft reflectors the virtual light source is not relevant, the surface becomes the source with no indication of the distance it travels to get there.

**** The traditional hard lights used in the film industry are either an open face light, PAR or Fresnel lens light, although all these lights have their place and are very useful in terms of control and function, they are often too hard to look completely natural in most situations and too soft to look like convincing sun rays.

The closest I ever got to convincing sun rays with artificial light was the old carbon arcs. However, since they are not available to use anymore the next best thing I've found is the Mole Richardson's mole beams. producing a parallel beam of hard light, similar to the PB70 they use a massive parabolic mirror to focus the light into a parallel beam. However, the optics and efficiency are nowhere near the dedolight PB70/30 and colour fringe appears quite badly on the edge of the beam and the homogeneity of the beam is very inconsistent.

EXCLUSIVE USE OF DEDOLIGHT LIGHTSTREAM LIGHTING IN COMMERCIALS SHOT BY BRITISH DOP IAN MURRAY



„Heinz“



„Amazon“

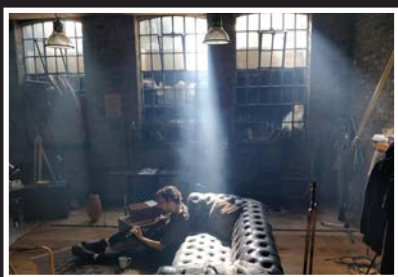

„Barbour“





„Chess“



„Arthritis“



„Dignity TVC“





„Direct Line“



„Paddy Power“



„McDonalds“



„Makemon“

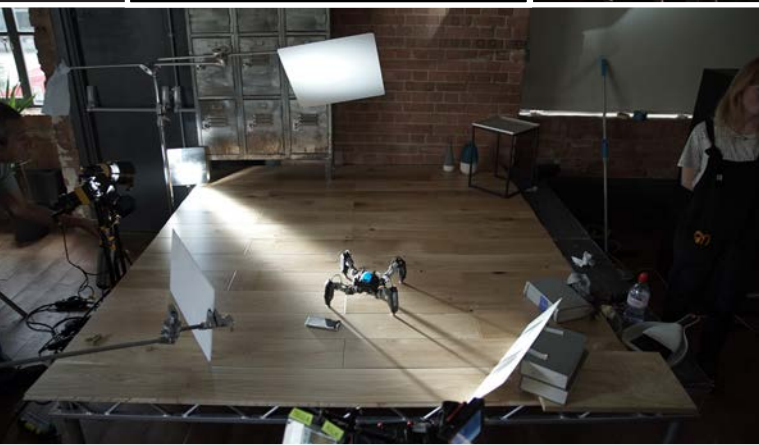



„Music video“



„TM Lewin Christmas“



„Privilege“



„TM Lewin Rugby“





François Aubry
Filmmaker,
Cinematographer,
LEADING PICTURES INC.

François Aubry is a filmmaker since 30 years. His fields of exploration are cinematography, writing, directing, editing and visual effects with the clear focus to offering extended creative service to fellow producers and directors, pushing the limits of possibilities, and offer solutions to production challenges. He also shares his knowledge and experience in film schools, colleges and universities, inspiring the passion of filmmaking to a new generation of filmmakers.

Francois Aubry entered the **National Film Board of Canada** as Director and writer of short animated films and received direct training from the initial team that created the effect cinematography for 2001; A Space Odyssey such as Sydney Goldsmith (animated visual effects), Eric Chamberlain (cinematography),

Colin Low (special effects), Werner Nold (editing). After 10 bright years of uninterrupted work at the NFB, signing 4 productions as Director, Writer and Animator, and 16 more as Visual Effects Supervisor, Aubry left the Board to take on even broader horizons.

Moving quickly to the front of his field, he began winning international contracts and collaborating with directors such as Denys Arcand and Robert Lepage, (Jesus of Montreal, Le Polygraphe), Atom Egoyan, Patricia Rozema, Thom Fitzgerald, (The Hanging Garden), and Andy Morahan (Highlander III) for the effect cinematography and visual effect design of feature fiction movies, documentaries, television series, short movies & music videos.

The new dedolight Lightstream® system has revolutionized my approach to lighting. Not only in the professional commercials, documentaries, and dramatic sets where I practice my art, but also in the teaching of light in film schools where I try my best to make students understand the intricate nature of light.

With parallel beams and virtual sources transmitted through a series of reflectors that all have their unique speed, texture, and inherent character, it's like a dream come true. We now can modulate light like a sculptor gives shape to his clay, and form clear expressions of light/energy onto our subjects with much control. Combines with the bicolour LEDRAPTOR® ambiance lighting, and the DMX controls of all the new line of DLED series, and the ability to project background textures with projector attachments, slides and gobos, and now the parallel beam intensifiers that multiply the output sometimes up to 5 times the amount at the focus settings, and a wide variety of added features such as angle expanders, and all the sophisticated tools to cut and mask light with rotating barn-doors and what not, we can now realize our most complex dreams with ease and grace.

For years I've been building my own lights because of the inability of standard instruments to give me the desired range and precision that I really need specially when lighting miniatures for animation or visual effects. How many times the standard lighting instruments have burned, even caught fire because of the black wrap covering them in order to create the exact snoot effect that I wanted. But not any more. dedolight does what I want them to do. They never burn or over-heat, and they are safe enough that I use them when filming around kids. The kids on my sets often help me to set the lights, so easy and straightforward they are, that a kid of 10 years old can set them up with no further instructions. So it's with delight that I recommend all of dedolight instruments. If they seem a bit pricy sometimes compared to knockoffs that pretend to do the same thing, don't be fooled. In the long run, these lights will pay for themselves, not only in bulb replacement, and electrical meter savings, but by the sheer power to deliver a high and precise output with much less hands on the set and a much faster preflight setting time. What I am talking about here, is man/time savings, and as producers, we all know how quickly a movie set can turn into a cash absorbing nightmare.



SQUARE LAW

The inverse square law applies to point light sources or Fresnel lights and focusing lights:

Double the distance – one quarter of the light.

When the light source is close to the talent, this will produce the effect of changing light intensity as soon as the talent moves closer to the light source or further away.

In order to overcome these effects, we have several ways and thoughts:

1 – Place the light source far away from the talent, thus minimizing the relation between the actual distance covered by movement of talent and the change of light intensity.

When lighting indoors, there may be limitations, as to how far away you can place the light source.

2 – Indoors, with space limitations, you can use a hard reflector on the ceiling to create a larger distance between light source and your talent.

Please be aware, that with soft reflectors this effect cannot be achieved.

3 – The narrower you can spot your focusing light, the more you are creating a virtual light source, which is behind the actual light fixture, thus increasing the active distance between the virtual light source and your talent, which also minimizes the effect of intensity change caused by talent movements.

4 – Using a parallel light, the virtual light source is effective very far behind the actual light fixture – see pages 14-15, overcoming most of the ill effects of the square law.

5 – For focusing lights, Fresnel lights and such, you can use half scrims or graduated scrims to minimize the unwanted effect of the square law.

6 – We are the only ones who offer graduated grey filters for light fixtures, which also work wonders to eliminate the ill effects of the square law.

7 – For large areas of light emission, be it soft lights or large light-reflecting surfaces, the square law becomes less active at close proximity.

The lower effect of the square law may hold true, until the object or the person being lit is further away than two or three times the diameter of the light-emitting area.



Square Law - The Basics: point light source 

Twice the distance = 1/4 the light

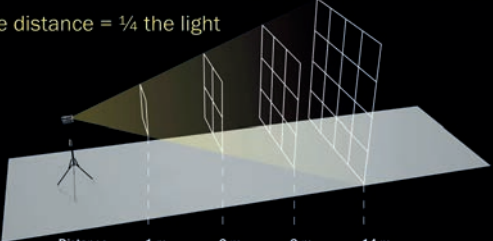

Distance:	1 m	2 m	3 m	14 m
Lit area:	1 m ²	4 m ²	9 m ²	16 m ²
Light quantity:	1/1	1/4	1/9	1/16
	100%	25%	11.11%	6.25%

Square Law - The Basics 

double distance = 1/4 light intensity

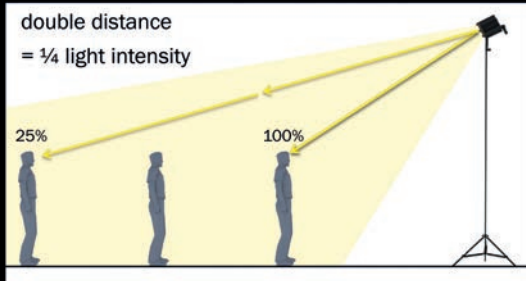

Unique Control - Graduated ND Filters 

DGRADF Set

Equal illumination levels, even when object is lit from an acute angle.

Transmission:

- 0.3ND = 50%
- 0.6ND = 25%
- 0.9ND = 12,5%

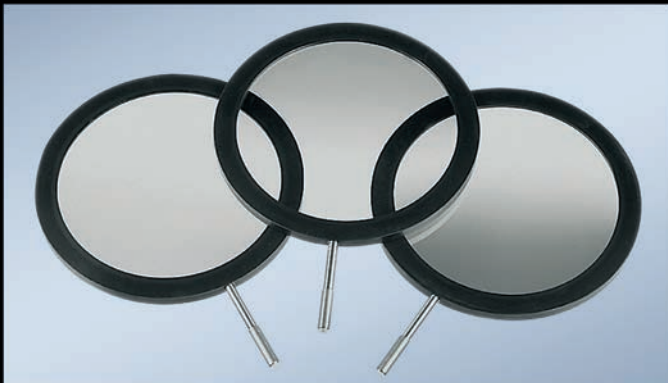

Unique Control - Graduated ND Filters 

with graduated gray glass filters (horizontal)

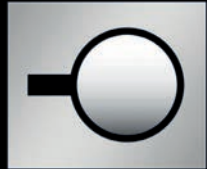

double distance = same intensity

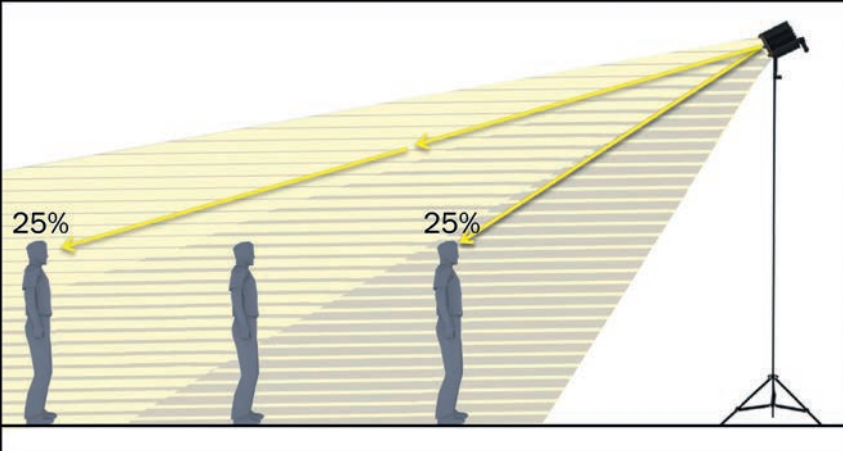

OPTIMIZER FILTERS

If you want to use the dedolight Lightstream parallel beam intensifiers for direct lighting (not necessarily with the reflectors), you may desire to smooth out the appearance of the maximum intensity position by adding the optimizer filters.

These filters exist in high-temperature plastic material, perfectly suitable for all of our focussing LED lights.

For ,hot lights', like our classic 150W focusing DLH4 light, and our DLH200DT light (the metal halide – HMI 200W light), as well as for the lights of the Series 400 (metal halide - HMI) and Series 1200, also metal halide – HMI, you will need high-temperature glass optimizers.

(see Codes in our price list)

DEDOLIGHT® LIGHTSTREAM PLAYLIST

All videos about dedolight Lightstream – present and future videos



Replicating the sun with "DPB70"

Adam Chambers, Gaffer in Hollywood, about his experience with the dedolight parallel beam light "DPB70" on location



A New Way of Lighting – dedolight® Lightstream

by Leading Pictures

A demonstration of the new lighting system given in June 2018 in Toronto Canada with cinematographer Dedo Weigert and an introduction by cinematographer François Aubry.



dedolight® Lightstream at PHOTOKINA 2018

Interview with Dedo Weigert and Marc Ludwig at the Foto-TV live studio about reflected light and the PHOTOKINA Wedding Zone studio which was exclusively lit with the dedolight® Lightstream system in a combination of DPB70 parallel beam light head, reflectors and Ledraptor5 LED soft light.



Reflected light in TV studio

dedolight parallel beam lights and reflected light in news studios i24, Tel Aviv / Israel. Well organised softness and unlimited creative freedom, natural sunlight in a news room. Game changer in studio illumination.



LIGHTSTREAM - Reflected Light System

The Cine Reflect Lighting System (CRLS) provides a different way of lighting, using reflected light with a parallel beam to precisely direct the light. This creates a working environment which is free of cables, heat, and it is quick to make changes to the lighting. The results, using the CRLS system, have been described as producing "a very natural type of light."



The Beauty of Reflected Light

The biggest lightsource, the sun, sends out light that is almost perfectly parallel. In order to achieve a similar effect, luminaires with an almost parallel beam and a homogenous light distribution are needed.

The quality light - from hard to soft - and precisely defined shadows are achieved by use of high-tech reflectors.



A RIVER OF LIGHT - Interview with DoP Christian Berger about CRLS

by TOM POEDERBACH <http://www.poederbach.com>

I scheduled an interview with Christian Berger (DoP) for a Dutch magazine I write for. His departure point is the natural light which he imitates and then he goes from there. And so creating beautiful lit scenes and then adds just those details and nuances what makes it special. Using a light source with a parallel light beam like sunlight and some special surfaced reflectors.



IMAGES TAKEN DURING DEDO'S LIGHTING SEMINAR
IN VIENNA, AUSTRIA IN 2018



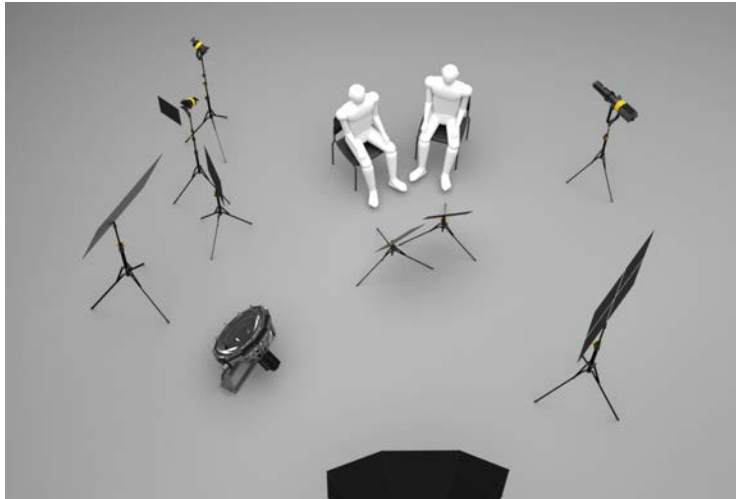

Here you find an animation
for this lighting setup





Dedo Weigert Film GmbH

Karl-Weinmair-Straße 10
D-80807 Munich, Germany

Phone: +49 - (0)89 - 356 16 01
Fax: +49 - (0)89 - 356 60 86

info@dedoweigertfilm.de
www.dedoweigertfilm.de